

Production Worksheet

Wilcom EmbroideryStudio - Designing



Design: **3**

Title:

Stitches: 6,258
 Height: 3.40 in
 Width: 3.50 in
 Colors: 2
 Colorway: Colorway 1
 Zoom: 1:1

Machine format: Tajima
 Color changes: 2
 Stops: 3
 Trims: 48
 Appliqués: 0
 Left: 44.2 mm
 Right: 44.7 mm
 Up: 41.9 mm
 Down: 44.3 mm
 EndX: 0.00 in
 EndY: 0.00 in
 Area 11.88 in²
 Max stitch: 9.7 mm
 Min stitch: 0.3 mm
 Max jump: 7.0 mm
 Total thread: 94.17ft
 Total bobbin: 30.89ft

Stop Sequence:

#	N#	Color	St.	Code	Name	Chart
1.	8	█	5,693	8	Black	Default
2.	9	□	363	9	White	Default
3.	8	█	200	8	Black	Default

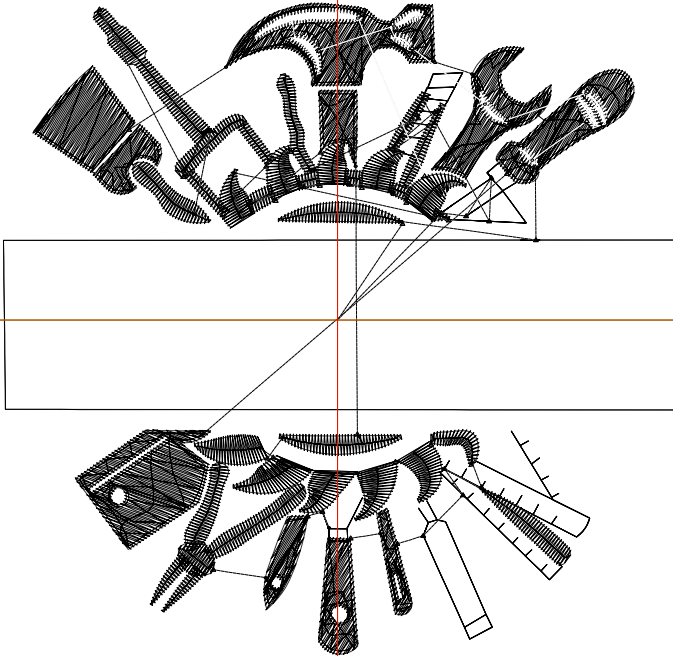

Production Worksheet

Wilcom EmbroideryStudio - Designing



Design: **4**

Title:

Stitches: 8,213
 Height: 4.36 in
 Width: 4.50 in
 Colors: 2
 Colorway: Colorway 1
 Zoom: 1:1

Machine format: Tajima
 Color changes: 2
 Stops: 3
 Trims: 50
 Appliqués: 0
 Left: 56.9 mm
 Right: 57.4 mm
 Up: 54.2 mm
 Down: 56.6 mm
 EndX: 0.00 in
 EndY: 0.00 in
 Area: 19.63 in²
 Max stitch: 7.0 mm
 Min stitch: 0.3 mm
 Max jump: 7.0 mm
 Total thread: 135.35ft
 Total bobbin: 47.69ft

Stop Sequence:

#	N#	Color	St.	Code	Name	Chart
1.	8	Black	7,500	8	Black	Default
2.	9	White	454	9	White	Default
3.	8	Black	257	8	Black	Default

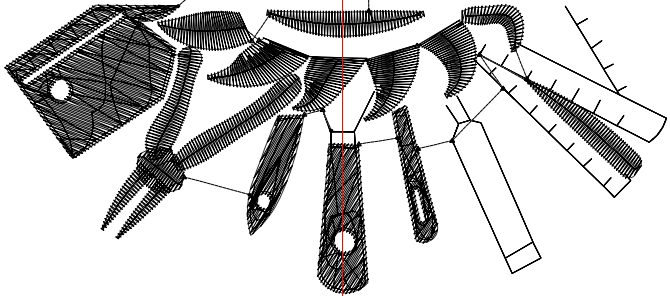
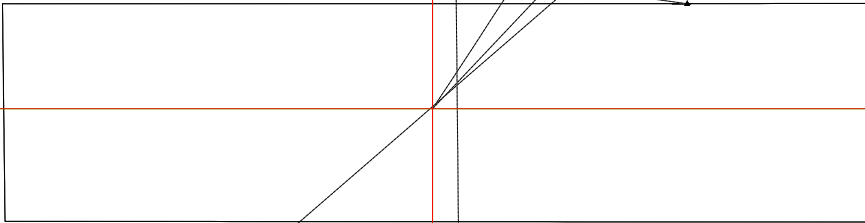
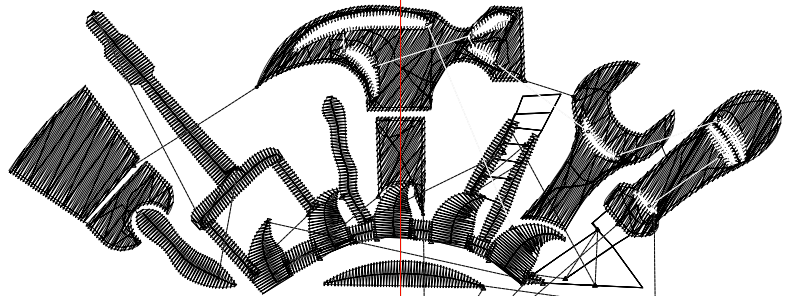

Production Worksheet

Wilcom EmbroideryStudio - Designing



Design: **5**

Title:

Stitches: 10,404
 Height: 5.33 in
 Width: 5.50 in
 Colors: 2
 Colorway: Colorway 1
 Zoom: 1:1

Machine format: Tajima
 Color changes: 2
 Stops: 3
 Trims: 51
 Appliqués: 0
 Left: 69.6 mm
 Right: 70.1 mm
 Up: 66.5 mm
 Down: 68.9 mm
 EndX: 0.00 in
 EndY: 0.00 in
 Area: 29.32 in²
 Max stitch: 7.0 mm
 Min stitch: 0.3 mm
 Max jump: 7.0 mm
 Total thread: 184.36ft
 Total bobbin: 68.21ft

Stop Sequence:

#	N#	Color	St.	Code	Name	Chart
1.	8		9,557	8	Black	Default
2.	9		532	9	White	Default
3.	8		313	8	Black	Default

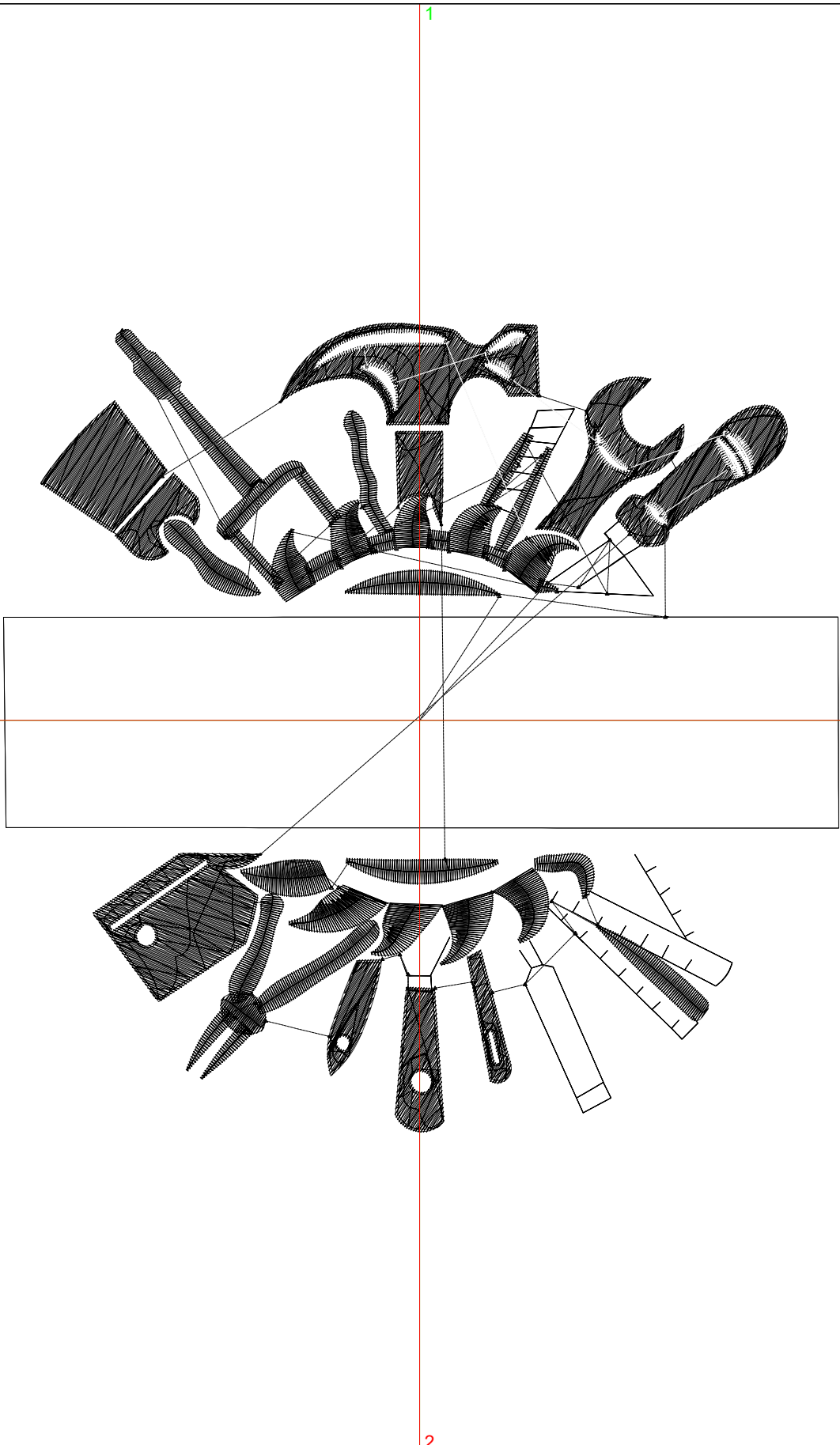

Production Worksheet

Wilcom EmbroideryStudio - Designing



Design: **6**

Title:

Stitches: 12,965
Height: 6.30 in
Width: 6.50 in
Colors: 2
Colorway: Colorway 1
Zoom: 1:1

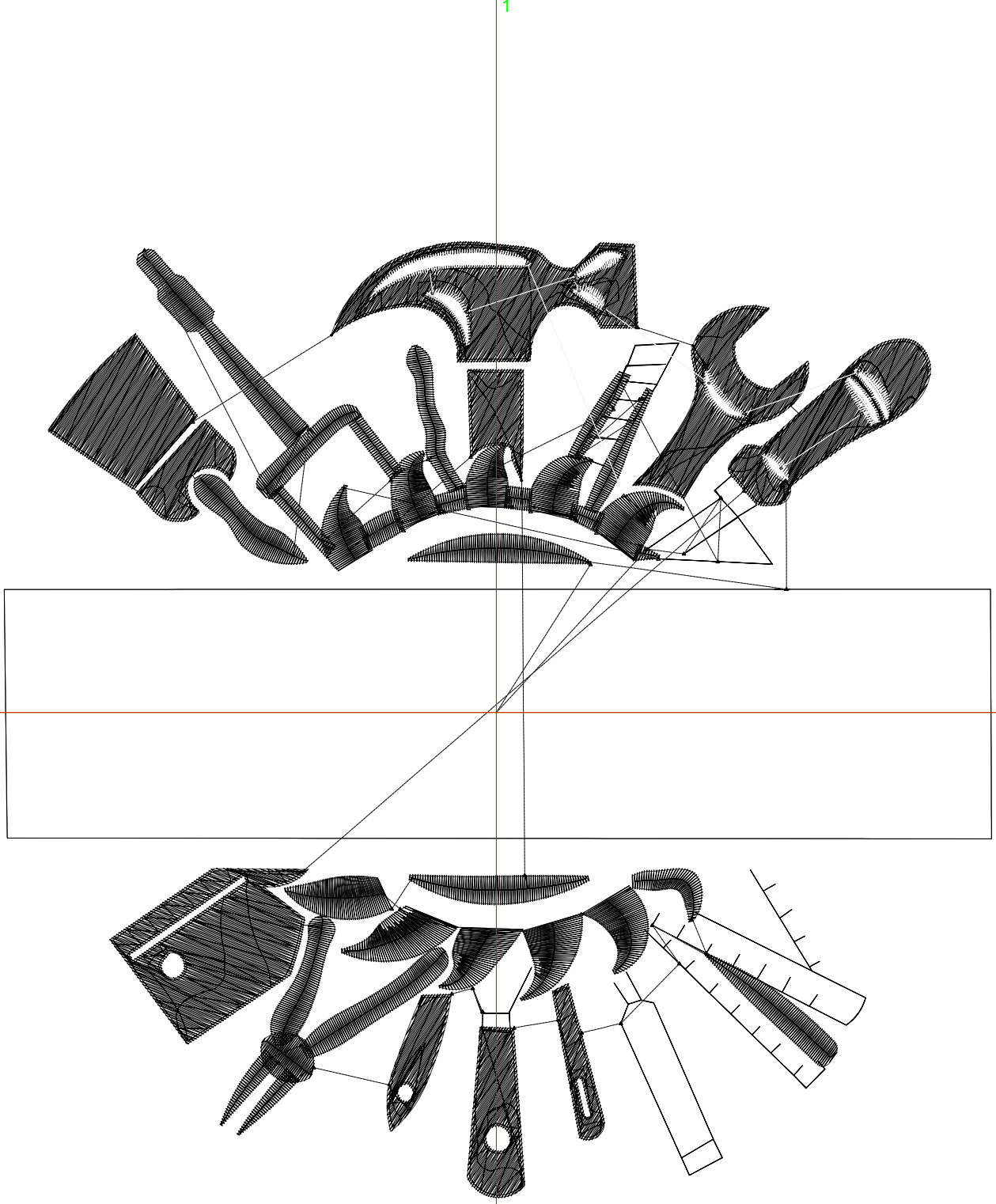

Production Worksheet

Wilcom EmbroideryStudio - Designing



Design: **6**

Title:

Stitches: 12,965
 Height: 6.30 in
 Width: 6.50 in
 Colors: 2
 Colorway: Colorway 1
 Zoom: 1:1

Machine format: Tajima
 Color changes: 2
 Stops: 3
 Trims: 52
 Appliqués: 0
 Left: 82.3 mm
 Right: 82.8 mm
 Up: 78.8 mm
 Down: 81.2 mm
 EndX: 0.00 in
 EndY: 0.00 in
 Area 40.93 in²
 Max stitch: 7.0 mm
 Min stitch: 0.3 mm
 Max jump: 6.8 mm
 Total thread: 242.44ft
 Total bobbin: 92.67ft

Stop Sequence:

#	N#	Color	St.	Code	Name	Chart
1.	8		11,966	8	Black	Default
2.	9		628	9	White	Default
3.	8		369	8	Black	Default

Production Worksheet

Wilcom EmbroideryStudio - Designing



Design: **7**

Title:

Stitches: 15,703
Height: 7.26 in
Width: 7.50 in
Colors: 2
Colorway: Colorway 1
Zoom: 1:1

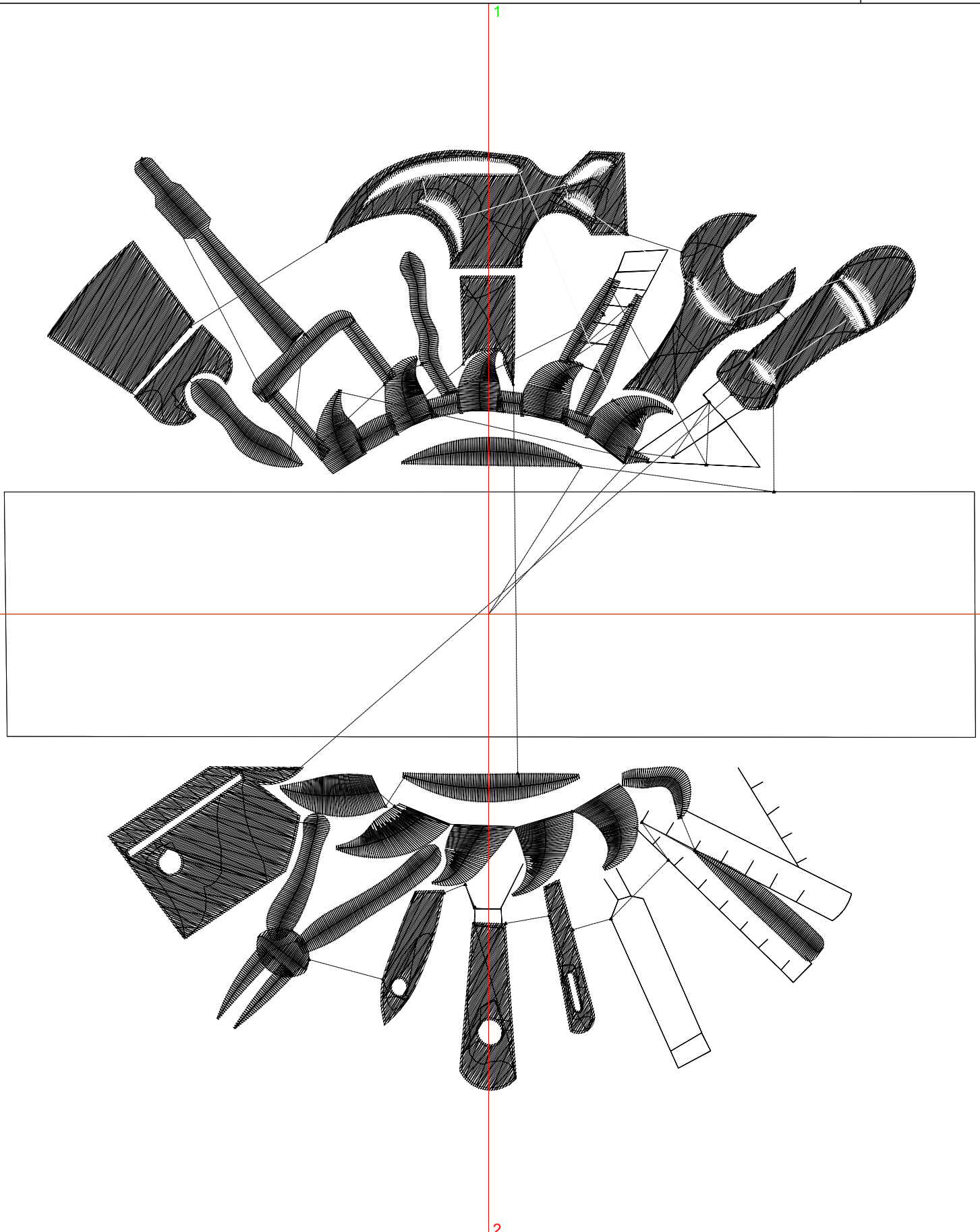

Production Worksheet

Wilcom EmbroideryStudio - Designing



Design: **7**

Title:

Stitches: 15,703
 Height: 7.26 in
 Width: 7.50 in
 Colors: 2
 Colorway: Colorway 1
 Zoom: 1:1

Machine format: Tajima
 Color changes: 2
 Stops: 3
 Trims: 53
 Appliqués: 0
 Left: 95.0 mm
 Right: 95.5 mm
 Up: 91.1 mm
 Down: 93.5 mm
 EndX: 0.00 in
 EndY: 0.00 in
 Area 54.49 in²
 Max stitch: 7.0 mm
 Min stitch: 0.2 mm
 Max jump: 7.0 mm
 Total thread: 308.77ft
 Total bobbin: 121.33ft

Stop Sequence:

#	N#	Color	St.	Code	Name	Chart
1.	8		14,555	8	Black	Default
2.	9		717	9	White	Default
3.	8		429	8	Black	Default