

# Production Worksheet

Wilcom EmbroideryStudio - Designing



Design: **3**

Title:

Stitches: 4,438  
 Height: 3.50 in  
 Width: 2.84 in  
 Colors: 1  
 Colorway: Colorway 1  
 Zoom: 1:1

Machine format: Tajima  
 Color changes: 0  
 Stops: 1  
 Trims: 31  
 Appliqués: 0  
 Left: 42.2 mm  
 Right: 30.0 mm  
 Up: 44.0 mm  
 Down: 45.0 mm  
 EndX: 0.00 in  
 EndY: 0.00 in  
 Area: 9.96 in<sup>2</sup>  
 Max stitch: 6.3 mm  
 Min stitch: 0.0 mm  
 Max jump: 6.8 mm  
 Total thread: 66.55ft  
 Total bobbin: 21.98ft

Stop Sequence:

#	N#	Color	St.	Code	Name	Chart
1.	8	█	4,436	8	Black	Default

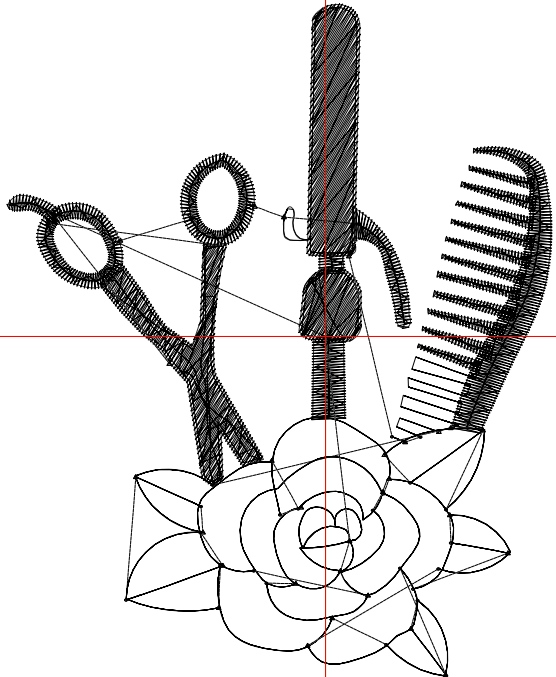

# Production Worksheet

Wilcom EmbroideryStudio - Designing



Design: **4**

Title:

Stitches: 5,837  
 Height: 4.50 in  
 Width: 3.65 in  
 Colors: 1  
 Colorway: Colorway 1  
 Zoom: 1:1

Machine format: Tajima  
 Color changes: 0  
 Stops: 1  
 Trims: 44  
 Appliqués: 0  
 Left: 52.4 mm  
 Right: 40.3 mm  
 Up: 56.8 mm  
 Down: 57.7 mm  
 EndX: 0.00 in  
 EndY: 0.00 in  
 Area: 16.44 in<sup>2</sup>  
 Max stitch: 6.8 mm  
 Min stitch: 0.0 mm  
 Max jump: 6.9 mm  
 Total thread: 95.24ft  
 Total bobbin: 33.55ft

Stop Sequence:

#	N#	Color	St.	Code	Name	Chart
1.	8	█	5,835	8	Black	Default

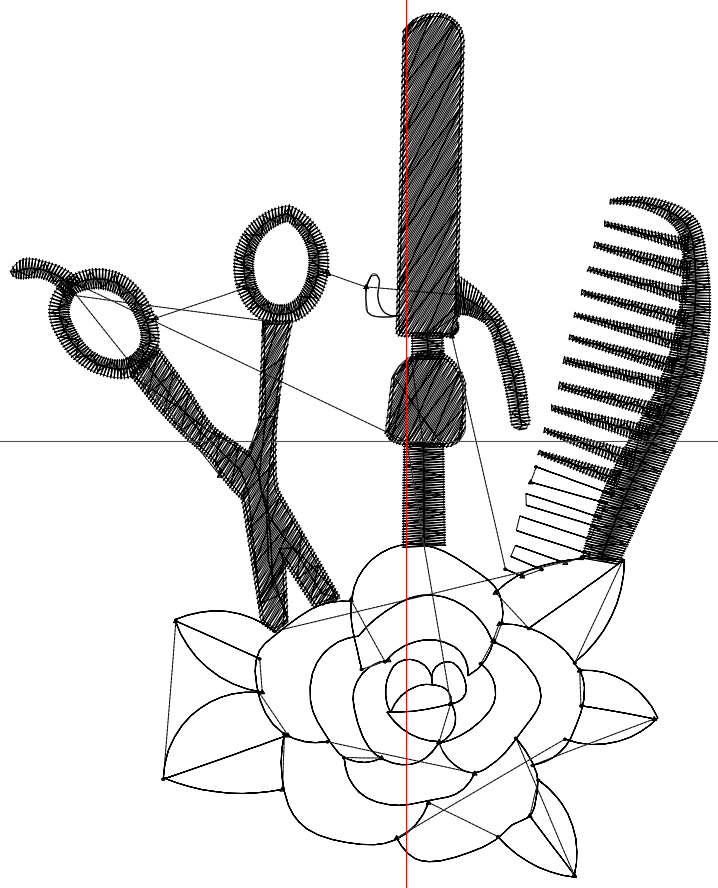

# Production Worksheet

Wilcom EmbroideryStudio - Designing



Design: **5**

Title:

Stitches: 7,290  
 Height: 5.50 in  
 Width: 4.46 in  
 Colors: 1  
 Colorway: Colorway 1  
 Zoom: 1:1

Machine format: Tajima  
 Color changes: 0  
 Stops: 1  
 Trims: 47  
 Appliqués: 0  
 Left: 62.7 mm  
 Right: 50.5 mm  
 Up: 69.4 mm  
 Down: 70.4 mm  
 EndX: 0.00 in  
 EndY: 0.00 in  
 Area: 24.55 in<sup>2</sup>  
 Max stitch: 7.2 mm  
 Min stitch: 0.0 mm  
 Max jump: 6.8 mm  
 Total thread: 128.71ft  
 Total bobbin: 47.73ft

Stop Sequence:

#	N#	Color	St.	Code	Name	Chart
1.	8	█	7,288	8	Black	Default

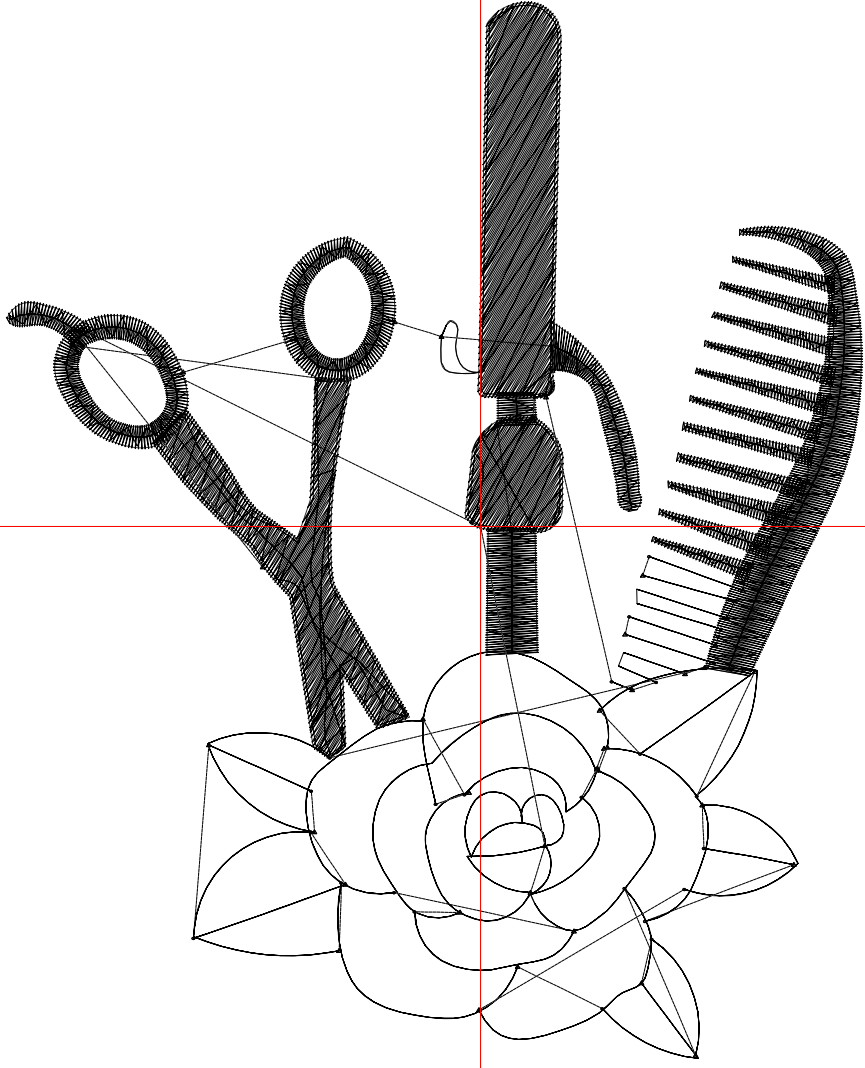

# Production Worksheet

Wilcom EmbroideryStudio - Designing



Design: **6**

Title:

Stitches: 8,849  
 Height: 6.50 in  
 Width: 5.27 in  
 Colors: 1  
 Colorway: Colorway 1  
 Zoom: 1:1

Machine format: Tajima  
 Color changes: 0  
 Stops: 1  
 Trims: 50  
 Appliqués: 0  
 Left: 73.0 mm  
 Right: 60.8 mm  
 Up: 82.1 mm  
 Down: 83.1 mm  
 EndX: 0.00 in  
 EndY: 0.00 in  
 Area: 34.27 in<sup>2</sup>  
 Max stitch: 8.4 mm  
 Min stitch: 0.0 mm  
 Max jump: 6.8 mm  
 Total thread: 167.05ft  
 Total bobbin: 64.39ft

Stop Sequence:  

#	N#	Color	St.	Code	Name	Chart
1.	8	Black	8,847	8	Black	Default

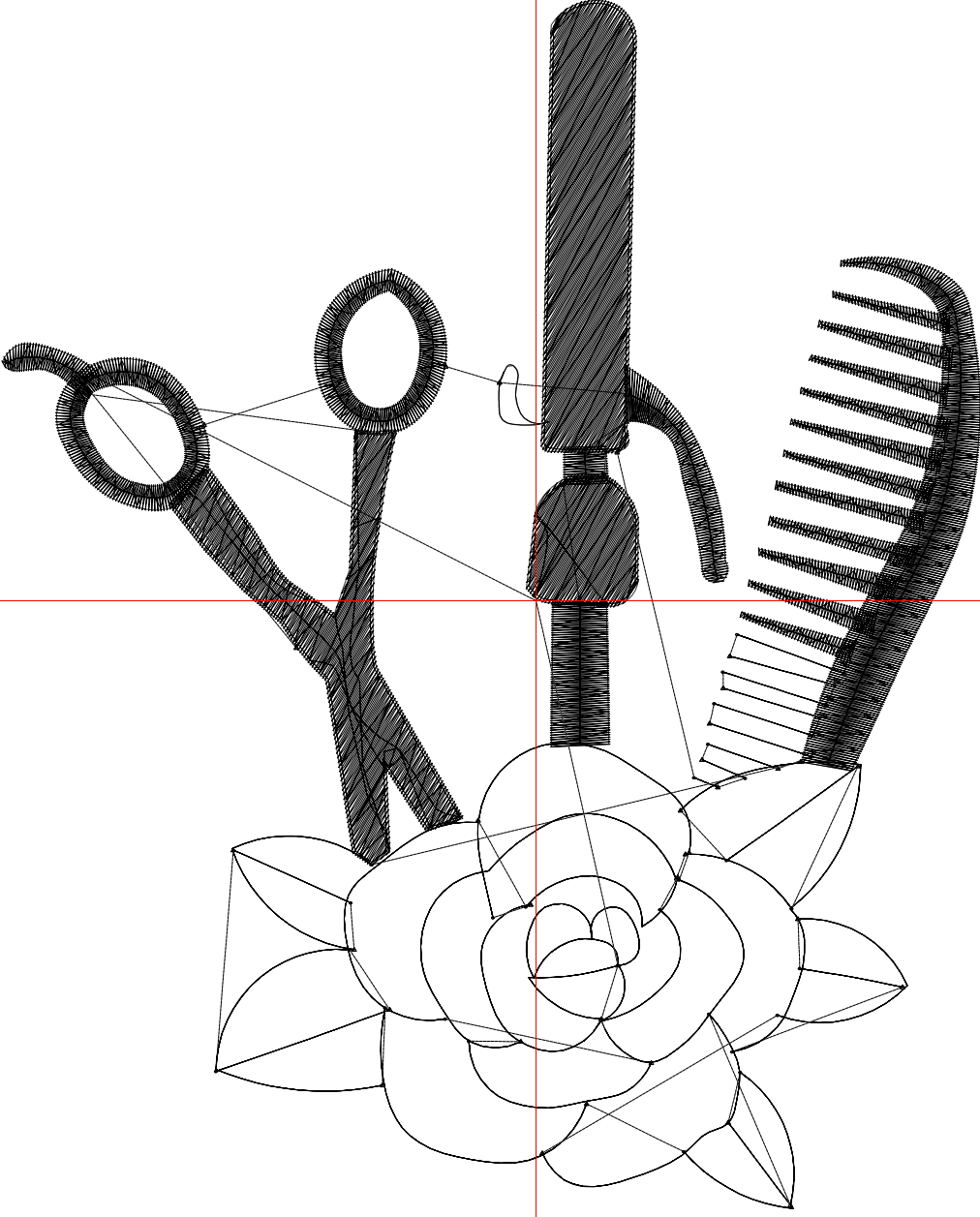

# Production Worksheet

Wilcom EmbroideryStudio - Designing



Design: **7**

Title:

Stitches: 10,467  
Height: 7.50 in  
Width: 6.08 in  
Colors: 1  
Colorway: Colorway 1  
Zoom: 1:1

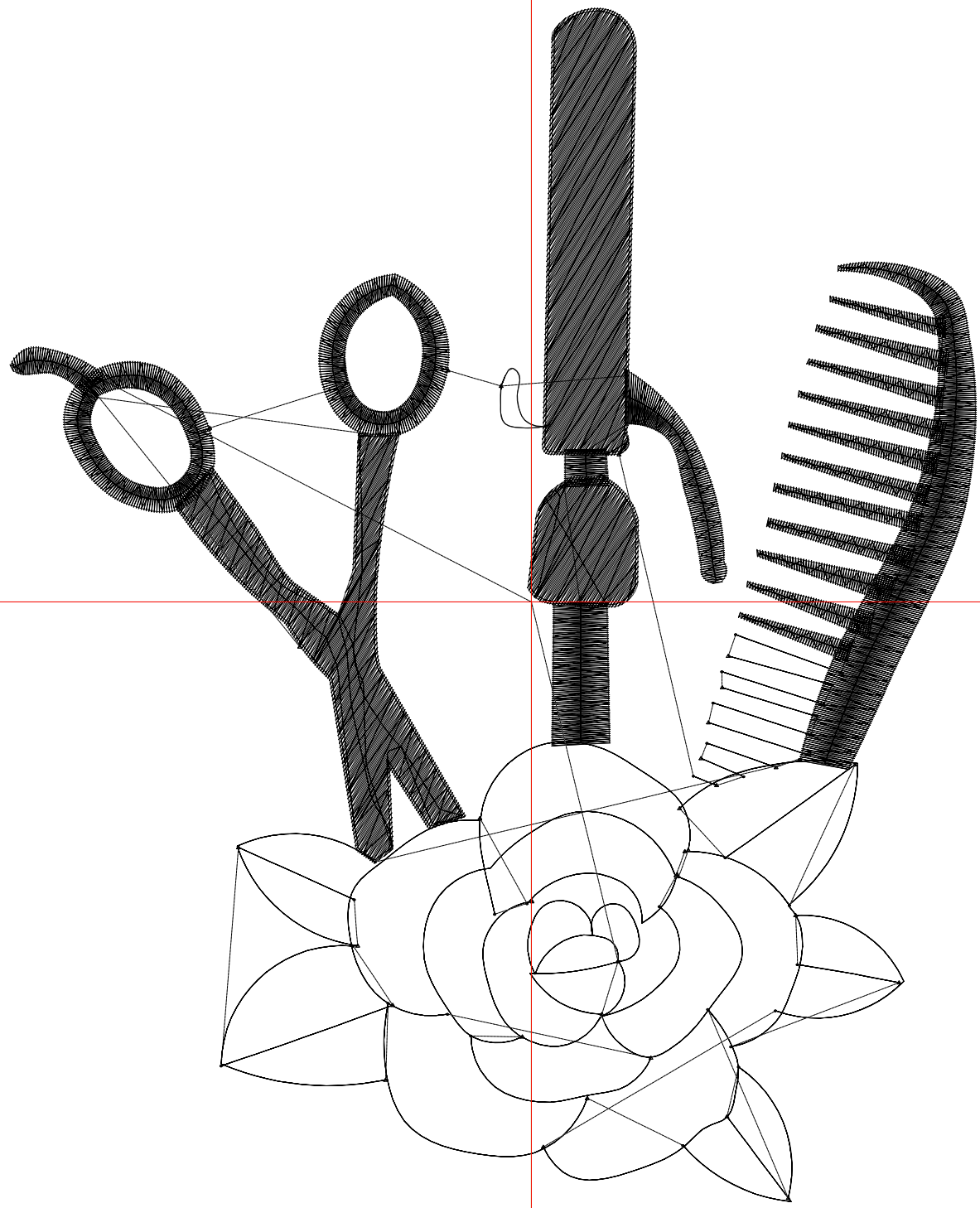

# Production Worksheet

Wilcom EmbroideryStudio - Designing



Design: **7**

Title:

Stitches: 10,467  
 Height: 7.50 in  
 Width: 6.08 in  
 Colors: 1  
 Colorway: Colorway 1  
 Zoom: 1:1

Machine format: Tajima  
 Color changes: 0  
 Stops: 1  
 Trims: 50  
 Appliqués: 0  
 Left: 83.3 mm  
 Right: 71.1 mm  
 Up: 94.8 mm  
 Down: 95.8 mm  
 EndX: 0.00 in  
 EndY: 0.00 in  
 Area 45.61 in<sup>2</sup>  
 Max stitch: 9.6 mm  
 Min stitch: 0.0 mm  
 Max jump: 7.0 mm  
 Total thread: 209.67ft  
 Total bobbin: 83.35ft

Stop Sequence:

#	N#	Color	St.	Code	Name	Chart
1.	8		10,465	8	Black	Default