

# Production Worksheet

Wilcom EmbroideryStudio - Designing



Design: **2**

Title:

Stitches: 2,994  
 Height: 2.00 in  
 Width: 2.50 in  
 Colors: 2  
 Colorway: Colorway 1  
 Zoom: 1:1

Machine format: Tajima  
 Color changes: 1  
 Stops: 2  
 Trims: 49  
 Appliqués: 0  
 Left: 31.5 mm  
 Right: 32.0 mm  
 Up: 23.2 mm  
 Down: 27.7 mm  
 EndX: 0.00 in  
 EndY: 0.00 in  
 Area 5.01 in<sup>2</sup>  
 Max stitch: 6.6 mm  
 Min stitch: 0.1 mm  
 Max jump: 6.6 mm  
 Total thread: 39.49ft  
 Total bobbin: 11.37ft

Stop Sequence:

#	N#	Color	St.	Code	Name	Chart
1.	2		1,095		R66 G117 B122	
2.	1		1,897		R0 G30 B51	

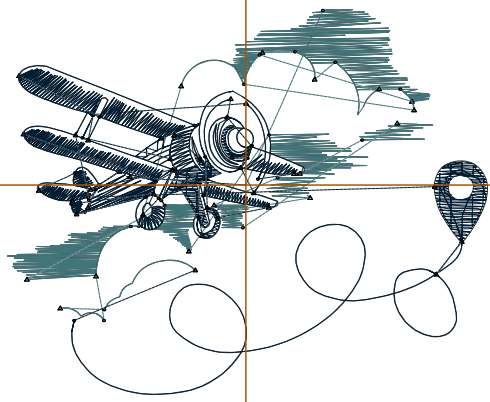

# Production Worksheet

Wilcom EmbroideryStudio - Designing



Design: **3**

Title:

Stitches: 3,409  
 Height: 2.41 in  
 Width: 3.00 in  
 Colors: 2  
 Colorway: Colorway 1  
 Zoom: 1:1

Machine format: Tajima  
 Color changes: 1  
 Stops: 2  
 Trims: 50  
 Appliqués: 0  
 Left: 37.9 mm  
 Right: 38.3 mm  
 Up: 28.3 mm  
 Down: 32.8 mm  
 EndX: 0.00 in  
 EndY: 0.00 in  
 Area 7.21 in<sup>2</sup>  
 Max stitch: 6.9 mm  
 Min stitch: 0.2 mm  
 Max jump: 6.9 mm  
 Total thread: 46.37ft  
 Total bobbin: 13.84ft

Stop Sequence:

#	N#	Color	St.	Code	Name	Chart
1.	2		1,261	R66	G117 B122	
2.	1		2,146	R0	G30 B51	

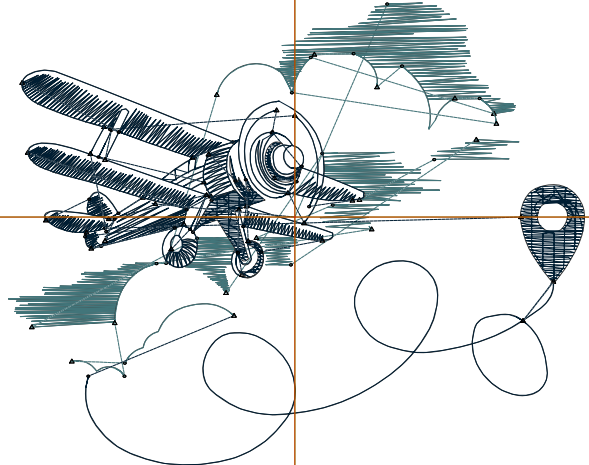

# Production Worksheet

Wilcom EmbroideryStudio - Designing



Design: **3**

Title:

Stitches: 3,868  
 Height: 2.81 in  
 Width: 3.50 in  
 Colors: 2  
 Colorway: Colorway 1  
 Zoom: 1:1

Machine format: Tajima  
 Color changes: 1  
 Stops: 2  
 Trims: 55  
 Appliqués: 0  
 Left: 44.2 mm  
 Right: 44.7 mm  
 Up: 33.4 mm  
 Down: 37.9 mm  
 EndX: 0.00 in  
 EndY: 0.00 in  
 Area 9.82 in<sup>2</sup>  
 Max stitch: 6.7 mm  
 Min stitch: 0.2 mm  
 Max jump: 6.7 mm  
 Total thread: 53.69ft  
 Total bobbin: 16.39ft

Stop Sequence:

#	N#	Color	St.	Code	Name	Chart
1.	2		1,393	R66	G117 B122	
2.	1		2,473	R0	G30 B51	

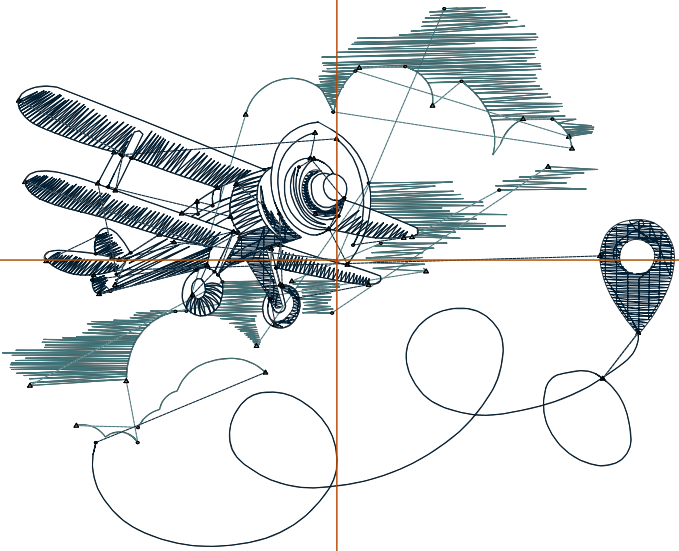

# Production Worksheet

Wilcom EmbroideryStudio - Designing



Design: **4**

Title:

Stitches: 4,290  
 Height: 3.21 in  
 Width: 4.00 in  
 Colors: 2  
 Colorway: Colorway 1  
 Zoom: 1:1

Machine format: Tajima  
 Color changes: 1  
 Stops: 2  
 Trims: 57  
 Appliqués: 0  
 Left: 50.6 mm  
 Right: 51.0 mm  
 Up: 38.5 mm  
 Down: 43.0 mm  
 EndX: 0.00 in  
 EndY: 0.00 in  
 Area: 12.83 in<sup>2</sup>  
 Max stitch: 6.7 mm  
 Min stitch: 0.3 mm  
 Max jump: 6.7 mm  
 Total thread: 60.81ft  
 Total bobbin: 18.97ft

Stop Sequence:

#	N#	Color	St.	Code	Name	Chart
1.	2		1,554	R66	G117 B122	
2.	1		2,734	R0	G30 B51	

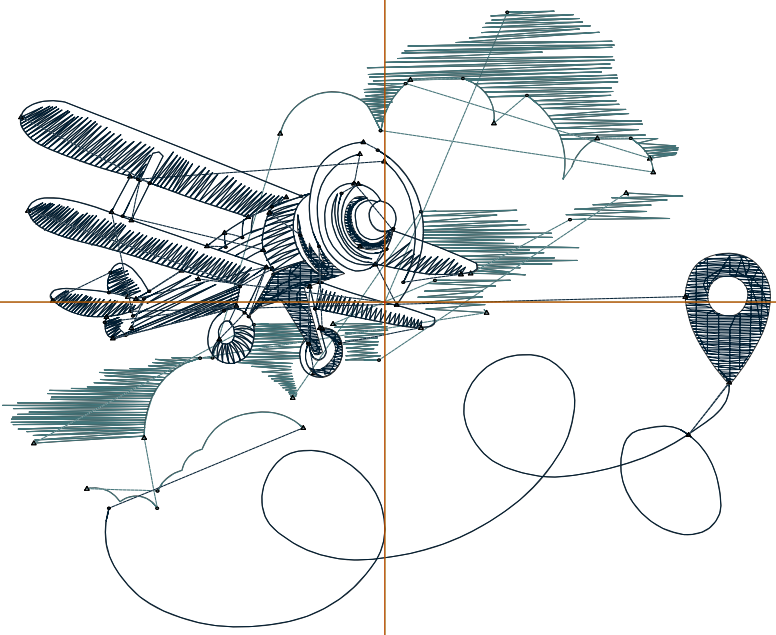

# Production Worksheet

Wilcom EmbroideryStudio - Designing



Design: **4**

Title:

Stitches: 4,734  
 Height: 3.61 in  
 Width: 4.50 in  
 Colors: 2  
 Colorway: Colorway 1  
 Zoom: 1:1

Machine format: Tajima  
 Color changes: 1  
 Stops: 2  
 Trims: 59  
 Appliqués: 0  
 Left: 56.9 mm  
 Right: 57.4 mm  
 Up: 43.6 mm  
 Down: 48.1 mm  
 EndX: 0.00 in  
 EndY: 0.00 in  
 Area: 16.24 in<sup>2</sup>  
 Max stitch: 6.9 mm  
 Min stitch: 0.2 mm  
 Max jump: 7.0 mm  
 Total thread: 68.34ft  
 Total bobbin: 21.70ft

Stop Sequence:

#	N#	Color	St.	Code	Name	Chart
1.	2		1,704	R66	G117 B122	
2.	1		3,028	R0	G30 B51	

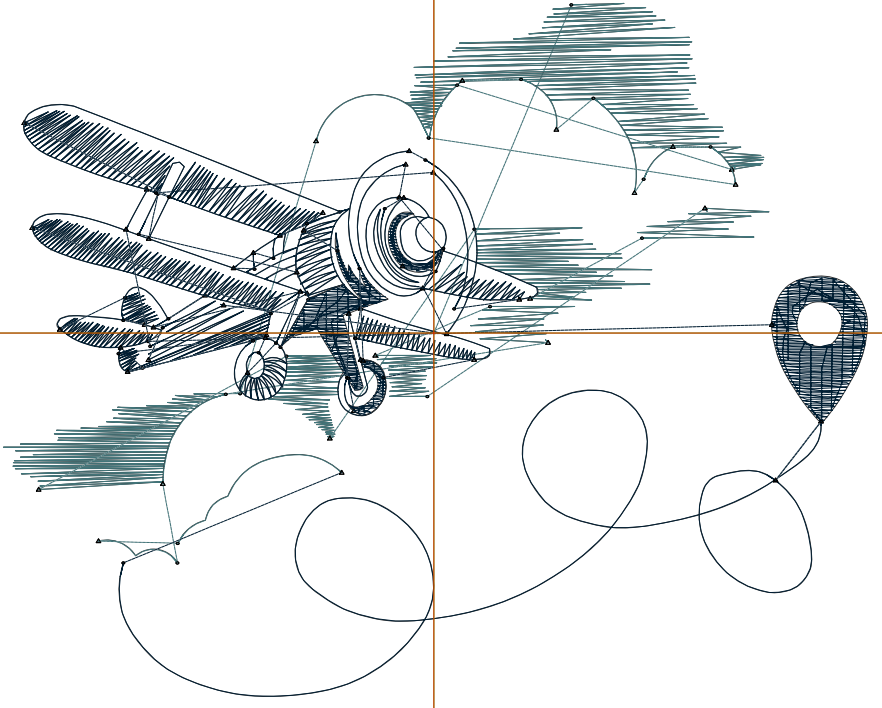

# Production Worksheet

Wilcom EmbroideryStudio - Designing



Design: **5**

Title:

Stitches: 5,183  
 Height: 4.01 in  
 Width: 5.00 in  
 Colors: 2  
 Colorway: Colorway 1  
 Zoom: 1:1

Machine format: Tajima  
 Color changes: 1  
 Stops: 2  
 Trims: 60  
 Appliqués: 0  
 Left: 63.3 mm  
 Right: 63.7 mm  
 Up: 48.7 mm  
 Down: 53.1 mm  
 EndX: 0.00 in  
 EndY: 0.00 in  
 Area: 20.04 in<sup>2</sup>  
 Max stitch: 6.9 mm  
 Min stitch: 0.3 mm  
 Max jump: 6.9 mm  
 Total thread: 75.94ft  
 Total bobbin: 24.46ft

Stop Sequence:

#	N#	Color	St.	Code	Name	Chart
1.	2		1,868	R66	G117 B122	
2.	1		3,313	R0	G30 B51	



# Production Worksheet

Wilcom EmbroideryStudio - Designing



Design: **5**

Title:

Stitches: 5,638  
Height: 4.41 in  
Width: 5.50 in  
Colors: 2  
Colorway: Colorway 1  
Zoom: 1:1

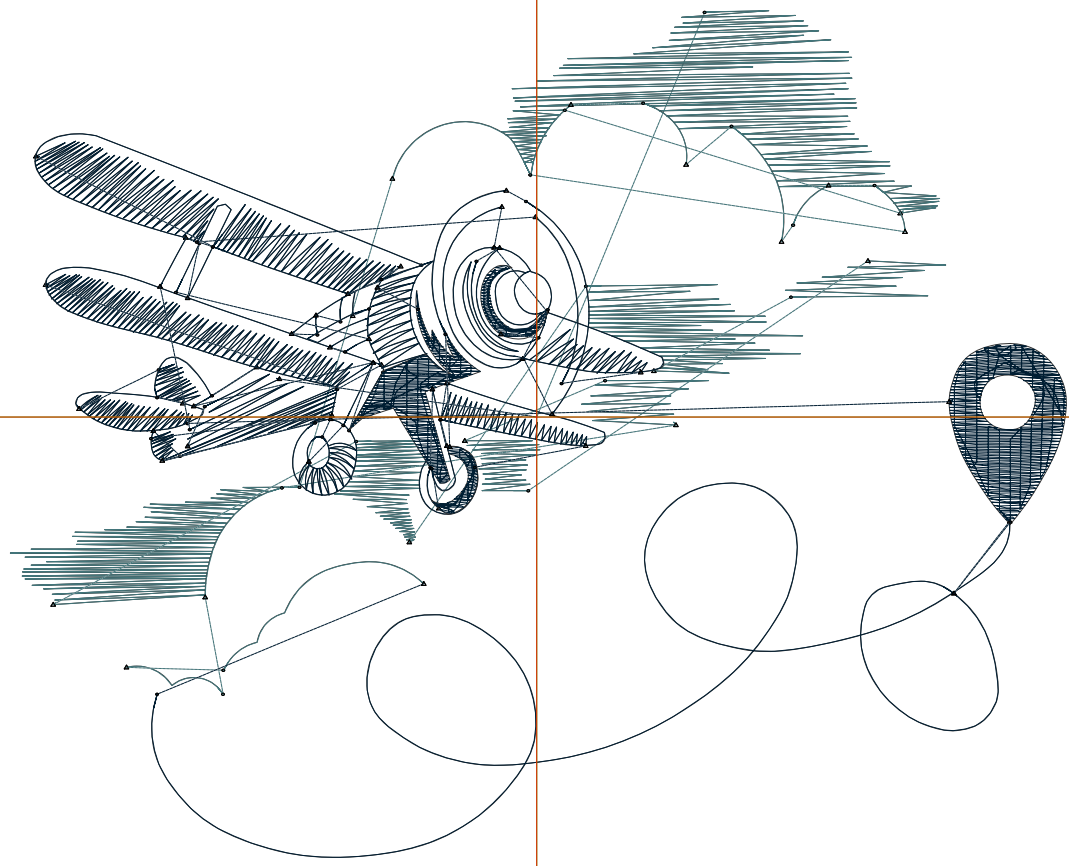

# Production Worksheet

Wilcom EmbroideryStudio - Designing



Design: **5**

Title:

Stitches: 5,638  
 Height: 4.41 in  
 Width: 5.50 in  
 Colors: 2  
 Colorway: Colorway 1  
 Zoom: 1:1

Machine format: Tajima  
 Color changes: 1  
 Stops: 2  
 Trims: 61  
 Appliqués: 0  
 Left: 69.6 mm  
 Right: 70.1 mm  
 Up: 53.8 mm  
 Down: 58.3 mm  
 EndX: 0.00 in  
 EndY: 0.00 in  
 Area 24.25 in<sup>2</sup>  
 Max stitch: 6.8 mm  
 Min stitch: 0.3 mm  
 Max jump: 6.8 mm  
 Total thread: 83.84ft  
 Total bobbin: 27.37ft

Stop Sequence:

#	N#	Color	St.	Code	Name	Chart
1.	2		2,025		R66 G117 B122	
2.	1		3,611		R0 G30 B51	

# Production Worksheet

Wilcom EmbroideryStudio - Designing



Design: **6**

Title:

Stitches: 6,059  
Height: 4.81 in  
Width: 6.00 in  
Colors: 2  
Colorway: Colorway 1  
Zoom: 1:1

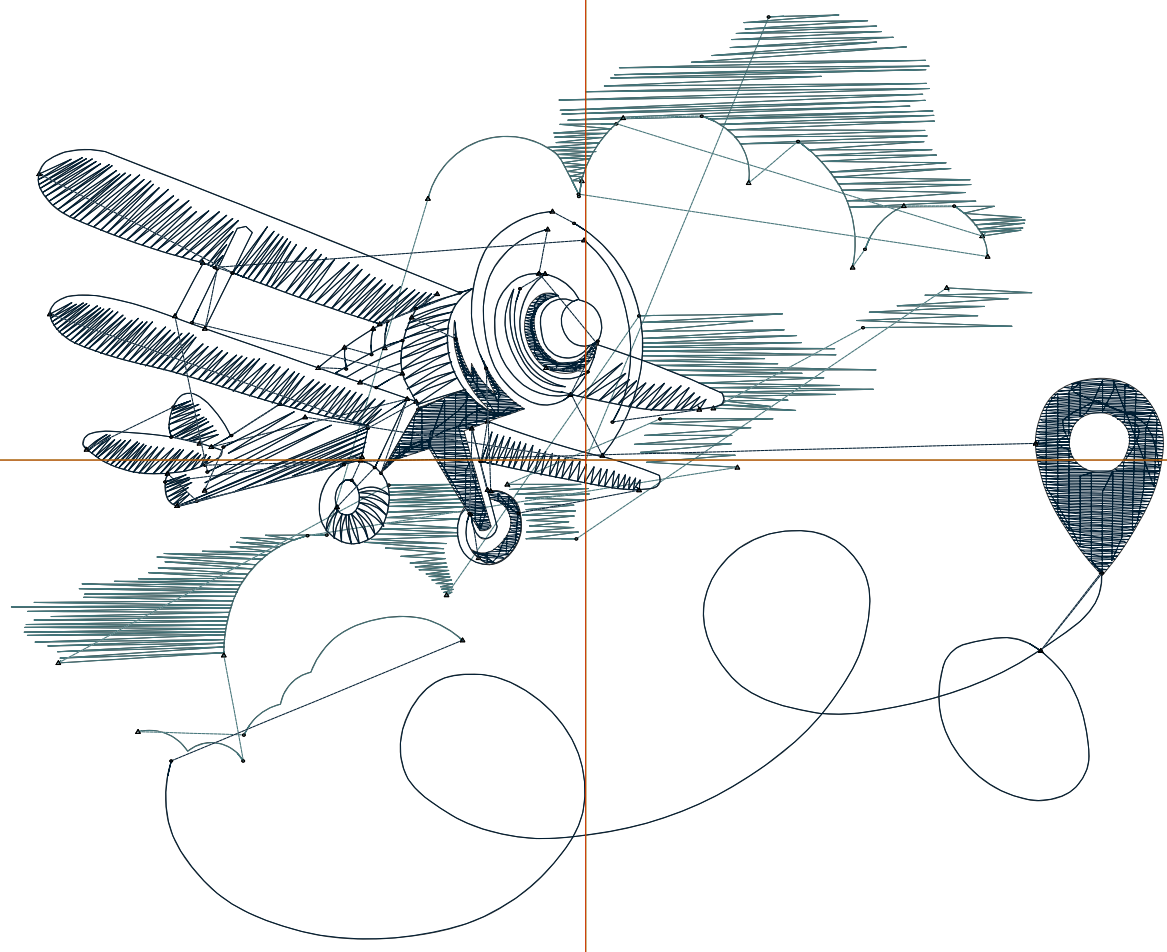

# Production Worksheet

Wilcom EmbroideryStudio - Designing



Design: **6**

Title:

Stitches: 6,059  
 Height: 4.81 in  
 Width: 6.00 in  
 Colors: 2  
 Colorway: Colorway 1  
 Zoom: 1:1

Machine format: Tajima  
 Color changes: 1  
 Stops: 2  
 Trims: 63  
 Appliqués: 0  
 Left: 76.0 mm  
 Right: 76.4 mm  
 Up: 58.9 mm  
 Down: 63.3 mm  
 EndX: 0.00 in  
 EndY: 0.00 in  
 Area 28.86 in<sup>2</sup>  
 Max stitch: 7.0 mm  
 Min stitch: 0.3 mm  
 Max jump: 7.0 mm  
 Total thread: 91.47ft  
 Total bobbin: 30.25ft

Stop Sequence:

#	N#	Color	St.	Code	Name	Chart
1.	2		2,188	R66	G117 B122	
2.	1		3,869	R0	G30 B51	

# Production Worksheet

Wilcom EmbroideryStudio - Designing



Design: **6**

Title:

Stitches: 6,502  
Height: 5.21 in  
Width: 6.50 in  
Colors: 2  
Colorway: Colorway 1  
Zoom: 1:1

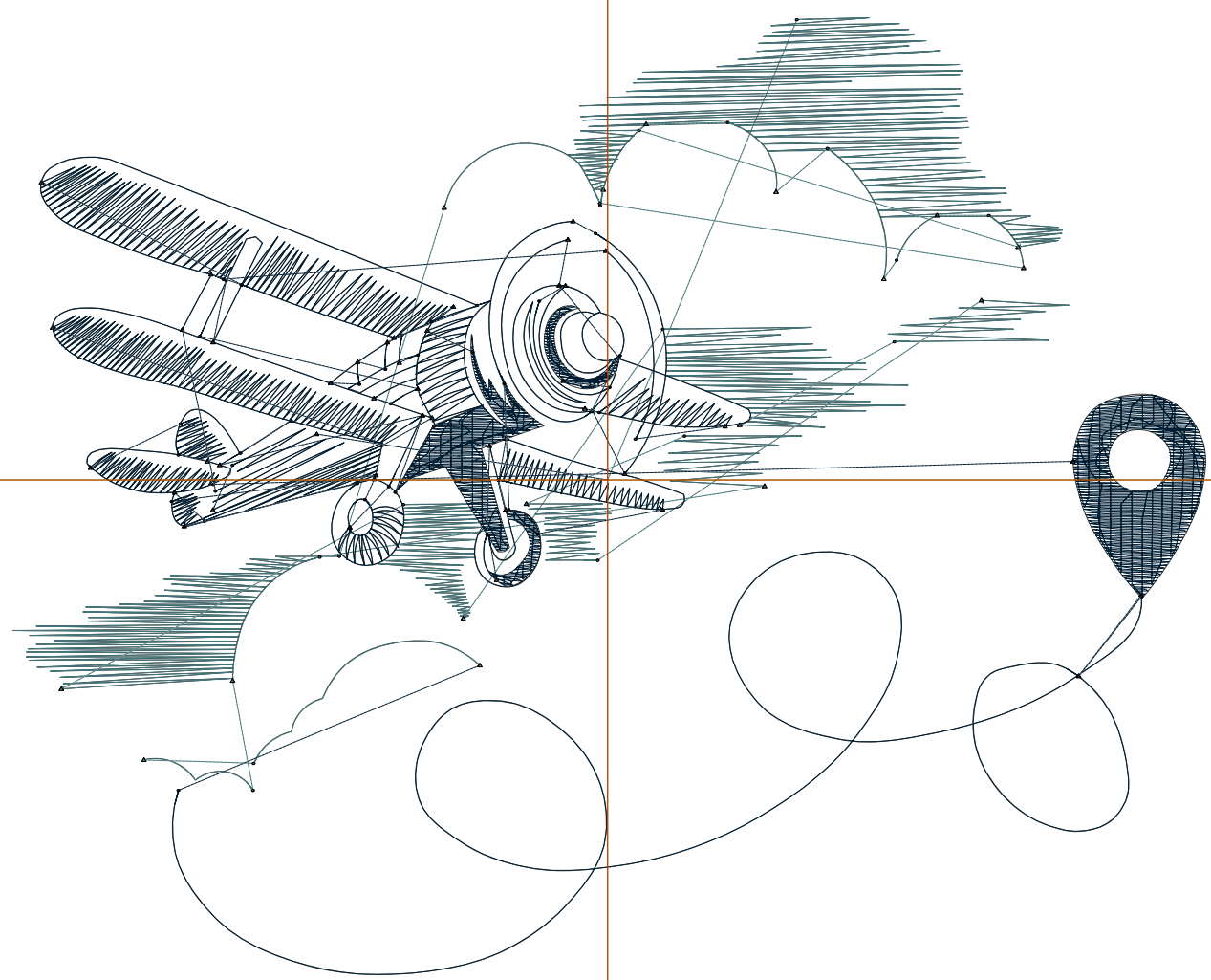

# Production Worksheet

Wilcom EmbroideryStudio - Designing



Design: **6**

Title:

Stitches: 6,502  
 Height: 5.21 in  
 Width: 6.50 in  
 Colors: 2  
 Colorway: Colorway 1  
 Zoom: 1:1

Machine format: Tajima  
 Color changes: 1  
 Stops: 2  
 Trims: 64  
 Appliqués: 0  
 Left: 82.3 mm  
 Right: 82.8 mm  
 Up: 64.0 mm  
 Down: 68.4 mm  
 EndX: 0.00 in  
 EndY: 0.00 in  
 Area 33.87 in<sup>2</sup>  
 Max stitch: 6.9 mm  
 Min stitch: 0.3 mm  
 Max jump: 7.0 mm  
 Total thread: 99.40ft  
 Total bobbin: 33.23ft

Stop Sequence:

#	N#	Color	St.	Code	Name	Chart
1.	2		2,345	R66	G117 B122	
2.	1		4,155	R0	G30 B51	

# Production Worksheet

Wilcom EmbroideryStudio - Designing



Design: **7**

Title:

Stitches: 7,003  
Height: 5.61 in  
Width: 7.00 in  
Colors: 2  
Colorway: Colorway 1  
Zoom: 1:1

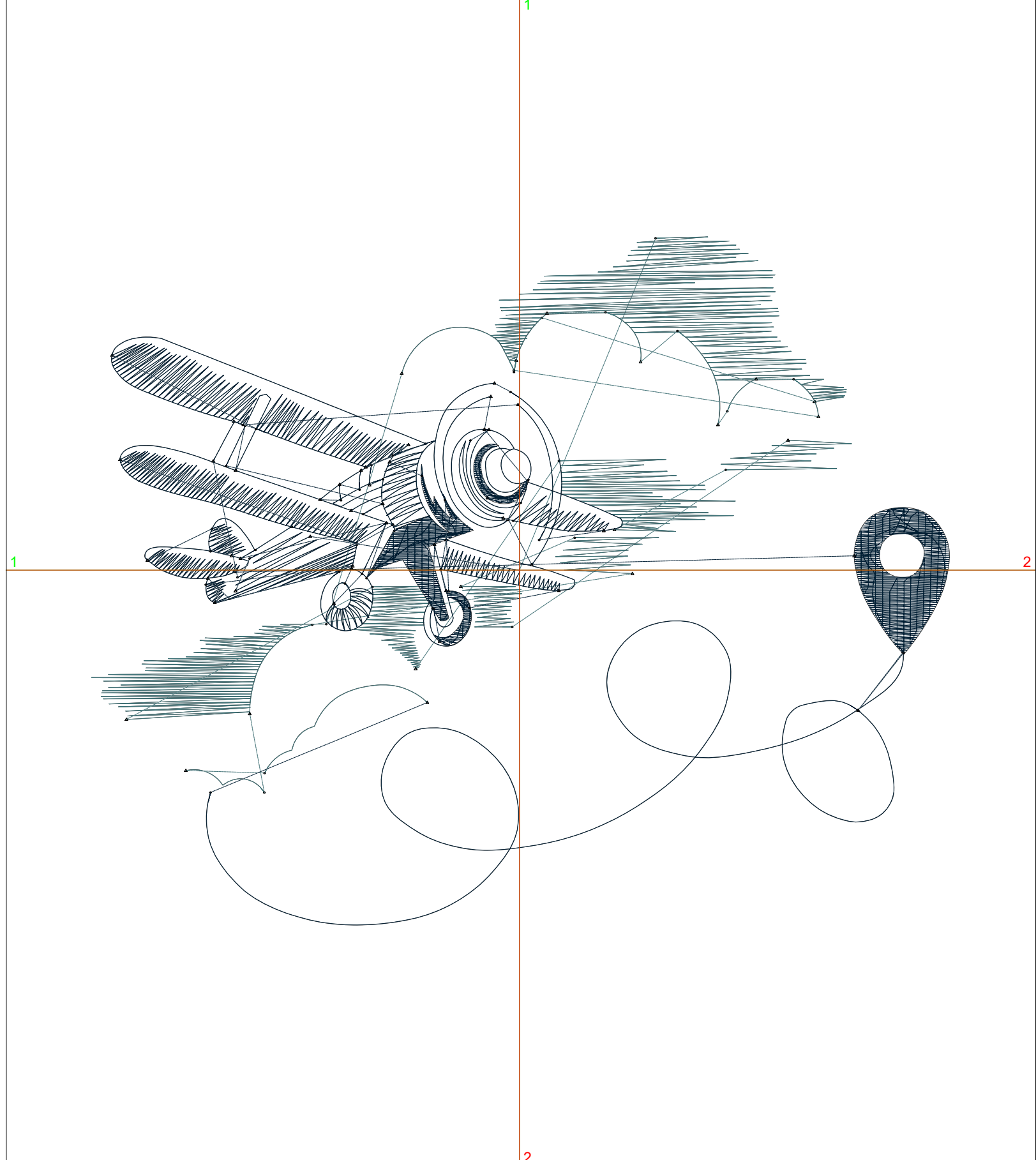

# Production Worksheet

Wilcom EmbroideryStudio - Designing



Design: **7**

Title:

Stitches: 7,003  
 Height: 5.61 in  
 Width: 7.00 in  
 Colors: 2  
 Colorway: Colorway 1  
 Zoom: 1:1

Machine format: Tajima  
 Color changes: 1  
 Stops: 2  
 Trims: 64  
 Appliqués: 0  
 Left: 88.7 mm  
 Right: 89.1 mm  
 Up: 69.1 mm  
 Down: 73.5 mm  
 EndX: 0.00 in  
 EndY: 0.00 in  
 Area 39.30 in<sup>2</sup>  
 Max stitch: 6.9 mm  
 Min stitch: 0.3 mm  
 Max jump: 6.9 mm  
 Total thread: 108.06ft  
 Total bobbin: 36.41ft

Stop Sequence:

#	N#	Color	St.	Code	Name	Chart
1.	2		2,492		R66 G117 B122	
2.	1		4,509		R0 G30 B51	

# Production Worksheet

Wilcom EmbroideryStudio - Designing



Design: **7**

Title:

Stitches: 7,495  
Height: 6.01 in  
Width: 7.50 in  
Colors: 2  
Colorway: Colorway 1  
Zoom: 1:1

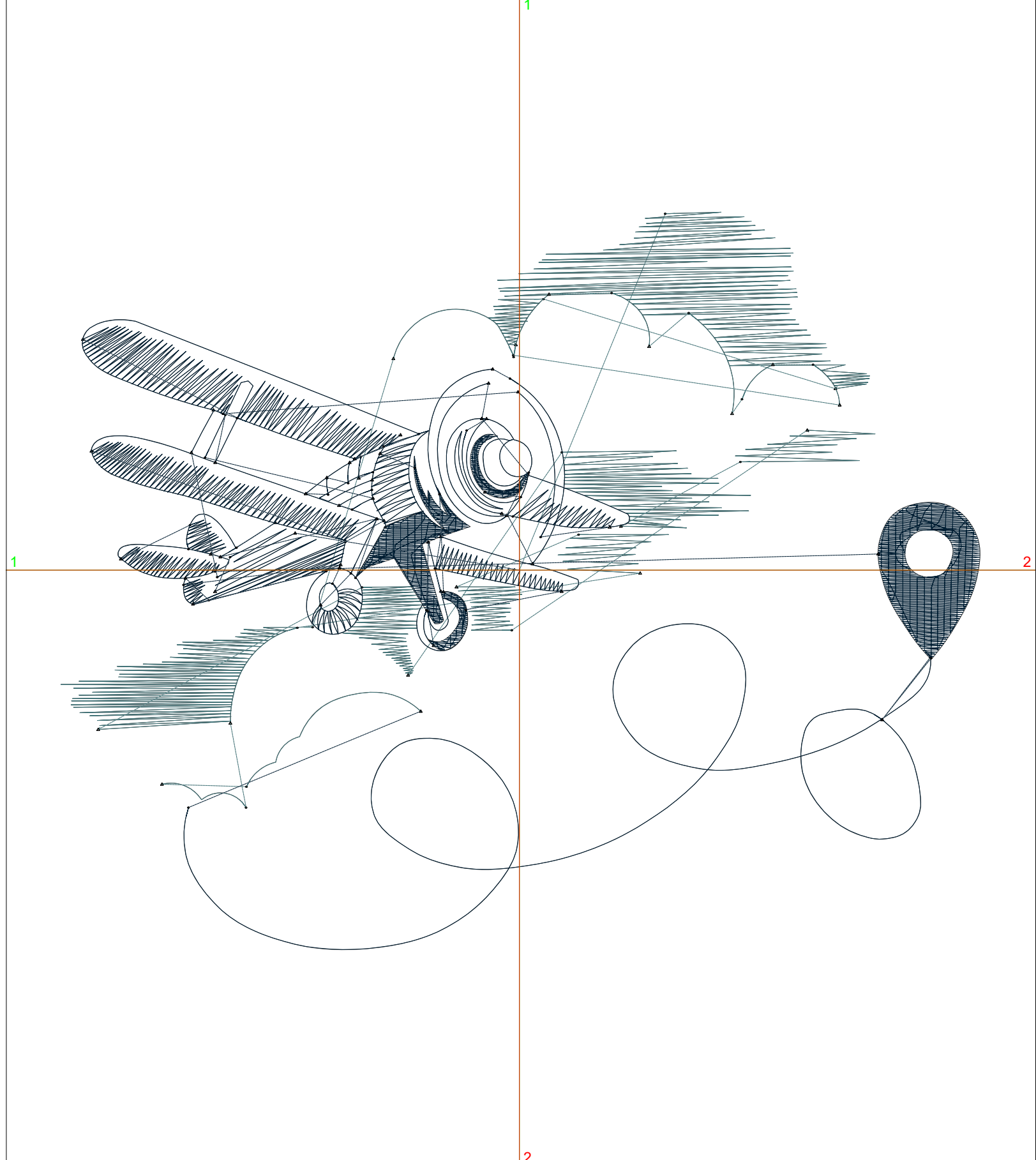

# Production Worksheet

Wilcom EmbroideryStudio - Designing



Design: **7**

Title:

Stitches: 7,495  
 Height: 6.01 in  
 Width: 7.50 in  
 Colors: 2  
 Colorway: Colorway 1  
 Zoom: 1:1

Machine format: Tajima  
 Color changes: 1  
 Stops: 2  
 Trims: 65  
 Appliqués: 0  
 Left: 95.0 mm  
 Right: 95.4 mm  
 Up: 74.2 mm  
 Down: 78.6 mm  
 EndX: 0.00 in  
 EndY: 0.00 in  
 Area 45.10 in<sup>2</sup>  
 Max stitch: 7.0 mm  
 Min stitch: 0.1 mm  
 Max jump: 7.0 mm  
 Total thread: 116.65ft  
 Total bobbin: 39.59ft

Stop Sequence:

#	N#	Color	St.	Code	Name	Chart
1.	2		2,656		R66 G117 B122	
2.	1		4,837		R0 G30 B51	