

Production Worksheet

Wilcom EmbroideryStudio - Designing



Design: **3**

Title:

Stitches: 7,409
 Height: 1.38 in
 Width: 3.50 in
 Colors: 14
 Colorway: Colorway 1
 Zoom: 1:1

Machine format: Tajima
 Color changes: 15
 Stops: 16
 Trims: 66
 Appliqués: 0
 Left: 49.5 mm
 Right: 39.3 mm
 Up: 19.4 mm
 Down: 15.6 mm
 EndX: 0.00 in
 EndY: 0.00 in
 Area: 4.82 in²
 Max stitch: 10.0 mm
 Min stitch: 0.0 mm
 Max jump: 6.9 mm
 Total thread: 95.65ft
 Total bobbin: 24.76ft

Stop Sequence:

| # | N# | Color | St. | Code | Name | Chart |
|-----|----|-------|-------|------|----------------|---------|
| 1. | 3 | | 378 | | R158 G204 B160 | |
| 2. | 2 | | 176 | | R255 G188 B213 | |
| 3. | 5 | | 141 | | R235 G235 B138 | |
| 4. | 9 | | 448 | 9 | White | Default |
| 5. | 5 | | 197 | | R235 G235 B138 | |
| 6. | 15 | | 1,044 | 15 | Pink | Default |
| 7. | 7 | | 195 | | R27 G79 B20 | |
| 8. | 1 | | 974 | | R88 G153 B85 | |
| 9. | 9 | | 248 | 9 | White | Default |
| 10. | 6 | | 323 | | R212 G141 B71 | |
| 11. | 10 | | 27 | | R255 G170 B85 | |
| 12. | 11 | | 17 | | R127 G128 B122 | |
| 13. | 12 | | 183 | 12 | Orange | Default |
| 14. | 4 | | 1,042 | 4 | Yellow | Default |
| 15. | 14 | | 293 | 14 | Brown | Default |
| 16. | 8 | | 1,721 | 8 | Black | Default |

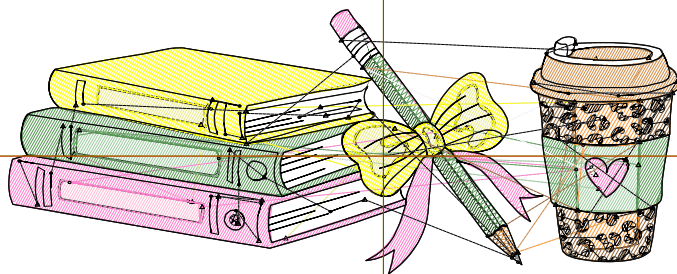

Production Worksheet

Wilcom EmbroideryStudio - Designing

Stitches: 8,617
 Height: 1.57 in
 Width: 4.00 in
 Colors: 14
 Colorway: Colorway 1
 Zoom: 1:1



Design: **4**

Title:

Machine format: Tajima
 Color changes: 15
 Stops: 16
 Trims: 67
 Appliqués: 0
 Left: 55.9 mm
 Right: 45.7 mm
 Up: 21.9 mm
 Down: 18.1 mm
 EndX: 0.00 in
 EndY: 0.00 in
 Area: 6.29 in²
 Max stitch: 11.4 mm
 Min stitch: 0.0 mm
 Max jump: 7.0 mm
 Total thread: 113.63ft
 Total bobbin: 30.72ft

Stop Sequence:

| # | N# | Color | St. | Code | Name | Chart |
|-----|----|-------|-------|------|----------------|---------|
| 1. | 3 | | 453 | | R158 G204 B160 | |
| 2. | 2 | | 208 | | R255 G188 B213 | |
| 3. | 5 | | 165 | | R235 G235 B138 | |
| 4. | 9 | | 530 | 9 | White | Default |
| 5. | 5 | | 224 | | R235 G235 B138 | |
| 6. | 15 | | 1,221 | 15 | Pink | Default |
| 7. | 7 | | 226 | | R27 G79 B20 | |
| 8. | 1 | | 1,172 | | R88 G153 B85 | |
| 9. | 9 | | 290 | 9 | White | Default |
| 10. | 6 | | 387 | | R212 G141 B71 | |
| 11. | 10 | | 28 | | R255 G170 B85 | |
| 12. | 11 | | 15 | | R127 G128 B122 | |
| 13. | 12 | | 213 | 12 | Orange | Default |
| 14. | 4 | | 1,223 | 4 | Yellow | Default |
| 15. | 14 | | 332 | 14 | Brown | Default |
| 16. | 8 | | 1,928 | 8 | Black | Default |

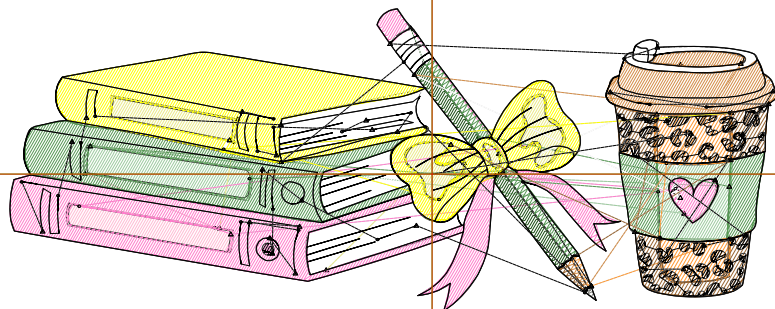

Production Worksheet

Wilcom EmbroideryStudio - Designing



Design: **4**

Title:

Stitches: 9,915
 Height: 1.77 in
 Width: 4.50 in
 Colors: 14
 Colorway: Colorway 1
 Zoom: 1:1

Machine format: Tajima
 Color changes: 15
 Stops: 16
 Trims: 68
 Appliqués: 0
 Left: 62.2 mm
 Right: 52.0 mm
 Up: 24.4 mm
 Down: 20.6 mm
 EndX: 0.00 in
 EndY: 0.00 in
 Area: 7.97 in²
 Max stitch: 6.9 mm
 Min stitch: 0.0 mm
 Max jump: 6.9 mm
 Total thread: 133.37ft
 Total bobbin: 37.37ft

Stop Sequence:

| # | N# | Color | St. | Code | Name | Chart |
|-----|----|-------|-------|------|----------------|---------|
| 1. | 3 | | 524 | | R158 G204 B160 | |
| 2. | 2 | | 241 | | R255 G188 B213 | |
| 3. | 5 | | 189 | | R235 G235 B138 | |
| 4. | 9 | | 632 | 9 | White | Default |
| 5. | 5 | | 259 | | R235 G235 B138 | |
| 6. | 15 | | 1,442 | 15 | Pink | Default |
| 7. | 7 | | 256 | | R27 G79 B20 | |
| 8. | 1 | | 1,377 | | R88 G153 B85 | |
| 9. | 9 | | 340 | 9 | White | Default |
| 10. | 6 | | 450 | | R212 G141 B71 | |
| 11. | 10 | | 31 | | R255 G170 B85 | |
| 12. | 11 | | 16 | | R127 G128 B122 | |
| 13. | 12 | | 244 | 12 | Orange | Default |
| 14. | 4 | | 1,430 | 4 | Yellow | Default |
| 15. | 14 | | 373 | 14 | Brown | Default |
| 16. | 8 | | 2,109 | 8 | Black | Default |

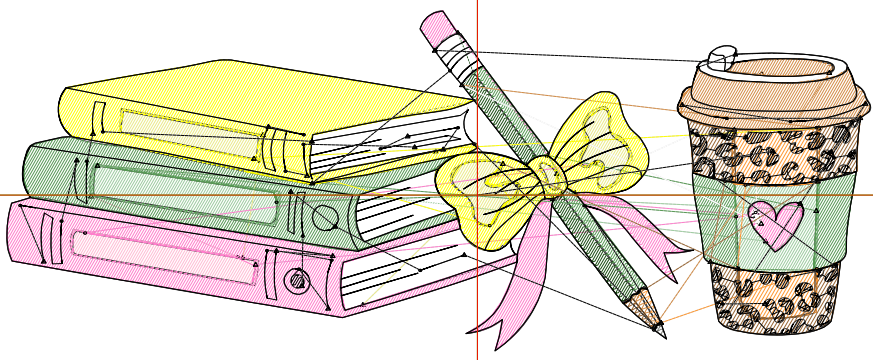

Production Worksheet

Wilcom EmbroideryStudio - Designing



Design: **5**

Title:

Stitches: 11,394
 Height: 1.97 in
 Width: 5.00 in
 Colors: 14
 Colorway: Colorway 1
 Zoom: 1:1

Machine format: Tajima
 Color changes: 15
 Stops: 16
 Trims: 70
 Appliqués: 0
 Left: 68.6 mm
 Right: 58.4 mm
 Up: 26.9 mm
 Down: 23.1 mm
 EndX: 0.00 in
 EndY: 0.00 in
 Area 9.84 in²
 Max stitch: 7.1 mm
 Min stitch: 0.0 mm
 Max jump: 7.0 mm
 Total thread: 156.24ft
 Total bobbin: 45.17ft

Stop Sequence:

| # | N# | Color | St. | Code | Name | Chart |
|-----|----|-------|-------|------|----------------|---------|
| 1. | 3 | | 602 | | R158 G204 B160 | |
| 2. | 2 | | 279 | | R255 G188 B213 | |
| 3. | 5 | | 217 | | R235 G235 B138 | |
| 4. | 9 | | 726 | 9 | White | Default |
| 5. | 5 | | 293 | | R235 G235 B138 | |
| 6. | 15 | | 1,651 | 15 | Pink | Default |
| 7. | 7 | | 290 | | R27 G79 B20 | |
| 8. | 1 | | 1,591 | | R88 G153 B85 | |
| 9. | 9 | | 397 | 9 | White | Default |
| 10. | 6 | | 526 | | R212 G141 B71 | |
| 11. | 10 | | 36 | | R255 G170 B85 | |
| 12. | 11 | | 23 | | R127 G128 B122 | |
| 13. | 12 | | 286 | 12 | Orange | Default |
| 14. | 4 | | 1,694 | 4 | Yellow | Default |
| 15. | 14 | | 423 | 14 | Brown | Default |
| 16. | 8 | | 2,358 | 8 | Black | Default |

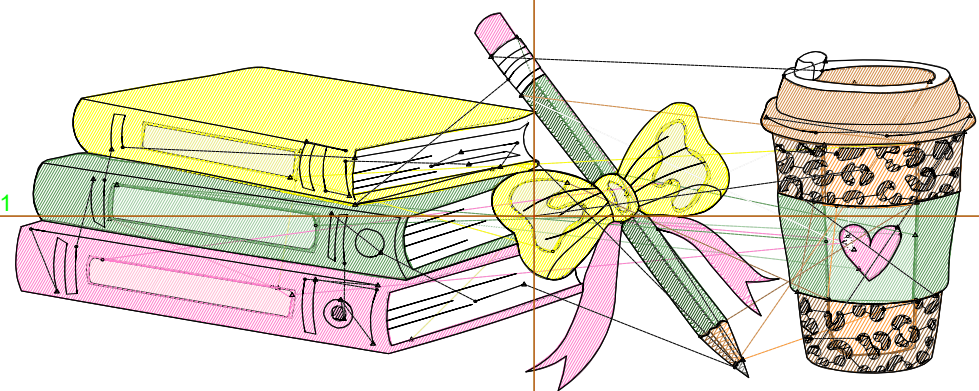

Production Worksheet

Wilcom EmbroideryStudio - Designing



Design: **5**

Title:

Stitches: 12,732
Height: 2.17 in
Width: 5.50 in
Colors: 14
Colorway: Colorway 1
Zoom: 1:1

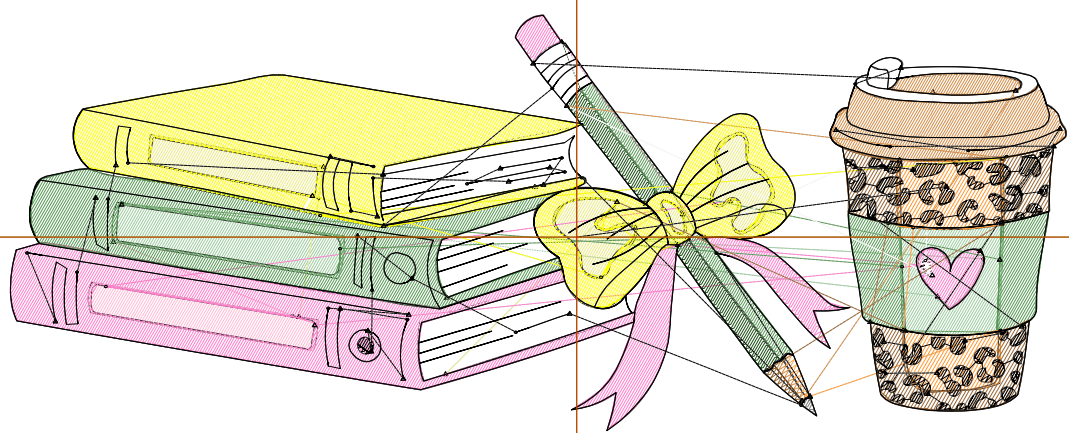

Production Worksheet

Wilcom EmbroideryStudio - Designing



Design: **5**

Title:

Stitches: 12,732
 Height: 2.17 in
 Width: 5.50 in
 Colors: 14
 Colorway: Colorway 1
 Zoom: 1:1

Machine format: Tajima
 Color changes: 15
 Stops: 16
 Trims: 73
 Appliqués: 0
 Left: 74.9 mm
 Right: 64.7 mm
 Up: 29.4 mm
 Down: 25.6 mm
 EndX: 0.00 in
 EndY: 0.00 in
 Area 11.90 in²
 Max stitch: 7.8 mm
 Min stitch: 0.0 mm
 Max jump: 7.0 mm
 Total thread: 177.93ft
 Total bobbin: 52.82ft

Stop Sequence:

| # | N# | Color | St. | Code | Name | Chart |
|-----|----|-------|-------|------|----------------|---------|
| 1. | 3 | | 682 | | R158 G204 B160 | |
| 2. | 2 | | 312 | | R255 G188 B213 | |
| 3. | 5 | | 246 | | R235 G235 B138 | |
| 4. | 9 | | 843 | 9 | White | Default |
| 5. | 5 | | 328 | | R235 G235 B138 | |
| 6. | 15 | | 1,854 | 15 | Pink | Default |
| 7. | 7 | | 326 | | R27 G79 B20 | |
| 8. | 1 | | 1,780 | | R88 G153 B85 | |
| 9. | 9 | | 448 | 9 | White | Default |
| 10. | 6 | | 591 | | R212 G141 B71 | |
| 11. | 10 | | 48 | | R255 G170 B85 | |
| 12. | 11 | | 24 | | R127 G128 B122 | |
| 13. | 12 | | 321 | 12 | Orange | Default |
| 14. | 4 | | 1,912 | 4 | Yellow | Default |
| 15. | 14 | | 479 | 14 | Brown | Default |
| 16. | 8 | | 2,536 | 8 | Black | Default |

Production Worksheet

Wilcom EmbroideryStudio - Designing



Design: **6**

Title:

Stitches: 14,216
Height: 2.36 in
Width: 6.00 in
Colors: 14
Colorway: Colorway 1
Zoom: 1:1

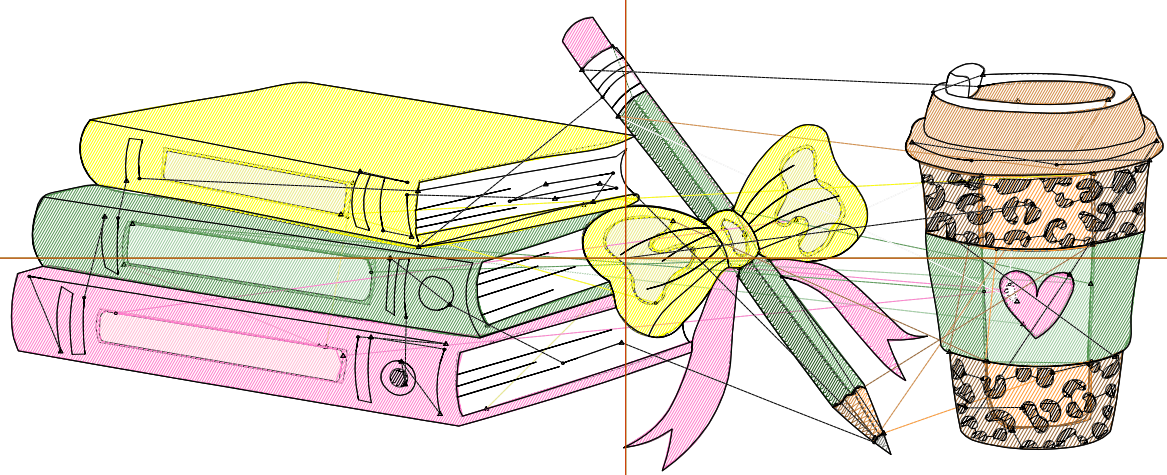

1

1

2

2

Production Worksheet

Wilcom EmbroideryStudio - Designing



Design: **6**

Title:

Stitches: 14,216
 Height: 2.36 in
 Width: 6.00 in
 Colors: 14
 Colorway: Colorway 1
 Zoom: 1:1

Machine format: Tajima
 Color changes: 15
 Stops: 16
 Trims: 74
 Appliqués: 0
 Left: 81.3 mm
 Right: 71.1 mm
 Up: 31.8 mm
 Down: 28.1 mm
 EndX: 0.00 in
 EndY: 0.00 in
 Area 14.16 in²
 Max stitch: 8.5 mm
 Min stitch: 0.0 mm
 Max jump: 7.0 mm
 Total thread: 202.57ft
 Total bobbin: 61.65ft

Stop Sequence:

| # | N# | Color | St. | Code | Name | Chart |
|-----|----|-------|-------|------|----------------|---------|
| 1. | 3 | | 772 | | R158 G204 B160 | |
| 2. | 2 | | 354 | | R255 G188 B213 | |
| 3. | 5 | | 279 | | R235 G235 B138 | |
| 4. | 9 | | 948 | 9 | White | Default |
| 5. | 5 | | 375 | | R235 G235 B138 | |
| 6. | 15 | | 2,093 | 15 | Pink | Default |
| 7. | 7 | | 359 | | R27 G79 B20 | |
| 8. | 1 | | 2,010 | | R88 G153 B85 | |
| 9. | 9 | | 480 | 9 | White | Default |
| 10. | 6 | | 668 | | R212 G141 B71 | |
| 11. | 10 | | 47 | | R255 G170 B85 | |
| 12. | 11 | | 26 | | R127 G128 B122 | |
| 13. | 12 | | 364 | 12 | Orange | Default |
| 14. | 4 | | 2,170 | 4 | Yellow | Default |
| 15. | 14 | | 526 | 14 | Brown | Default |
| 16. | 8 | | 2,743 | 8 | Black | Default |

Production Worksheet

Wilcom EmbroideryStudio - Designing



Design: **6**

Title:

Stitches: 15,813
Height: 2.56 in
Width: 6.50 in
Colors: 14
Colorway: Colorway 1
Zoom: 1:1

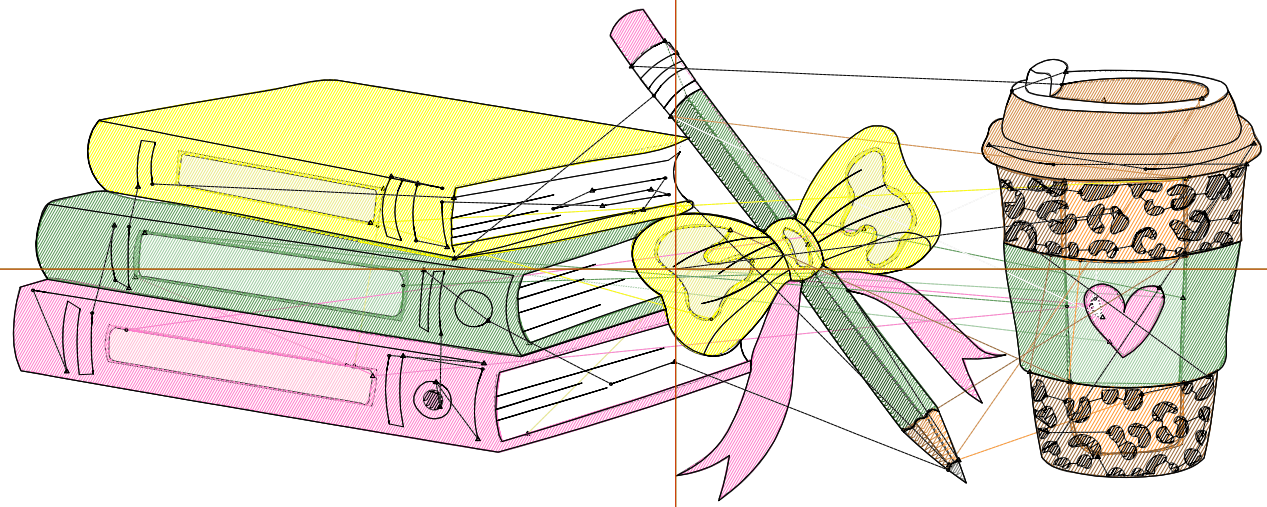

Production Worksheet

Wilcom EmbroideryStudio - Designing



Design: **6**

Title:

Stitches: 15,813
 Height: 2.56 in
 Width: 6.50 in
 Colors: 14
 Colorway: Colorway 1
 Zoom: 1:1

Machine format: Tajima
 Color changes: 15
 Stops: 16
 Trims: 77
 Appliqués: 0
 Left: 87.6 mm
 Right: 77.5 mm
 Up: 34.4 mm
 Down: 30.6 mm
 EndX: 0.00 in
 EndY: 0.00 in
 Area 16.63 in²
 Max stitch: 9.2 mm
 Min stitch: 0.0 mm
 Max jump: 7.0 mm
 Total thread: 229.19ft
 Total bobbin: 71.22ft

Stop Sequence:

| # | N# | Color | St. | Code | Name | Chart |
|-----|----|-------|-------|------|----------------|---------|
| 1. | 3 | | 862 | | R158 G204 B160 | |
| 2. | 2 | | 394 | | R255 G188 B213 | |
| 3. | 5 | | 305 | | R235 G235 B138 | |
| 4. | 9 | | 1,076 | 9 | White | Default |
| 5. | 5 | | 416 | | R235 G235 B138 | |
| 6. | 15 | | 2,360 | 15 | Pink | Default |
| 7. | 7 | | 396 | | R27 G79 B20 | |
| 8. | 1 | | 2,226 | | R88 G153 B85 | |
| 9. | 9 | | 532 | 9 | White | Default |
| 10. | 6 | | 747 | | R212 G141 B71 | |
| 11. | 10 | | 49 | | R255 G170 B85 | |
| 12. | 11 | | 31 | | R127 G128 B122 | |
| 13. | 12 | | 404 | 12 | Orange | Default |
| 14. | 4 | | 2,439 | 4 | Yellow | Default |
| 15. | 14 | | 593 | 14 | Brown | Default |
| 16. | 8 | | 2,981 | 8 | Black | Default |

Production Worksheet

Wilcom EmbroideryStudio - Designing



Design: **7**

Title:

Stitches: 17,420
Height: 2.76 in
Width: 7.00 in
Colors: 14
Colorway: Colorway 1
Zoom: 1:1

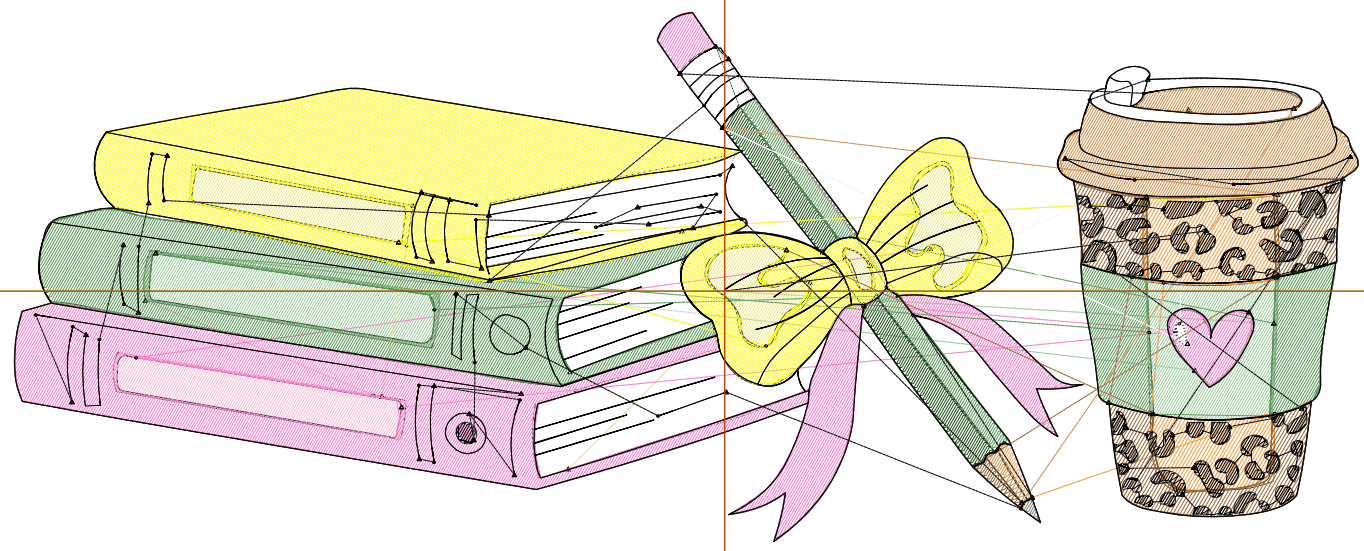

Production Worksheet

Wilcom EmbroideryStudio - Designing



Design: **7**

Title:

Stitches: 17,420
 Height: 2.76 in
 Width: 7.00 in
 Colors: 14
 Colorway: Colorway 1
 Zoom: 1:1

Machine format: Tajima
 Color changes: 15
 Stops: 16
 Trims: 84
 Appliqués: 0
 Left: 94.0 mm
 Right: 83.8 mm
 Up: 36.9 mm
 Down: 33.1 mm
 EndX: 0.00 in
 EndY: 0.00 in
 Area 19.28 in²
 Max stitch: 10.0 mm
 Min stitch: 0.0 mm
 Max jump: 7.0 mm
 Total thread: 256.30ft
 Total bobbin: 81.03ft

Stop Sequence:

| # | N# | Color | St. | Code | Name | Chart |
|-----|----|-------|-------|------|----------------|---------|
| 1. | 3 | | 956 | | R158 G204 B160 | |
| 2. | 2 | | 438 | | R255 G188 B213 | |
| 3. | 5 | | 337 | | R235 G235 B138 | |
| 4. | 9 | | 1,193 | 9 | White | Default |
| 5. | 5 | | 455 | | R235 G235 B138 | |
| 6. | 15 | | 2,580 | 15 | Pink | Default |
| 7. | 7 | | 435 | | R27 G79 B20 | |
| 8. | 1 | | 2,480 | | R88 G153 B85 | |
| 9. | 9 | | 582 | 9 | White | Default |
| 10. | 6 | | 838 | | R212 G141 B71 | |
| 11. | 10 | | 54 | | R255 G170 B85 | |
| 12. | 11 | | 34 | | R127 G128 B122 | |
| 13. | 12 | | 456 | 12 | Orange | Default |
| 14. | 4 | | 2,705 | 4 | Yellow | Default |
| 15. | 14 | | 649 | 14 | Brown | Default |
| 16. | 8 | | 3,226 | 8 | Black | Default |

Production Worksheet

Wilcom EmbroideryStudio - Designing



Design: **7**

Title:

Stitches: 19,108
Height: 2.95 in
Width: 7.50 in
Colors: 14
Colorway: Colorway 1
Zoom: 1:1

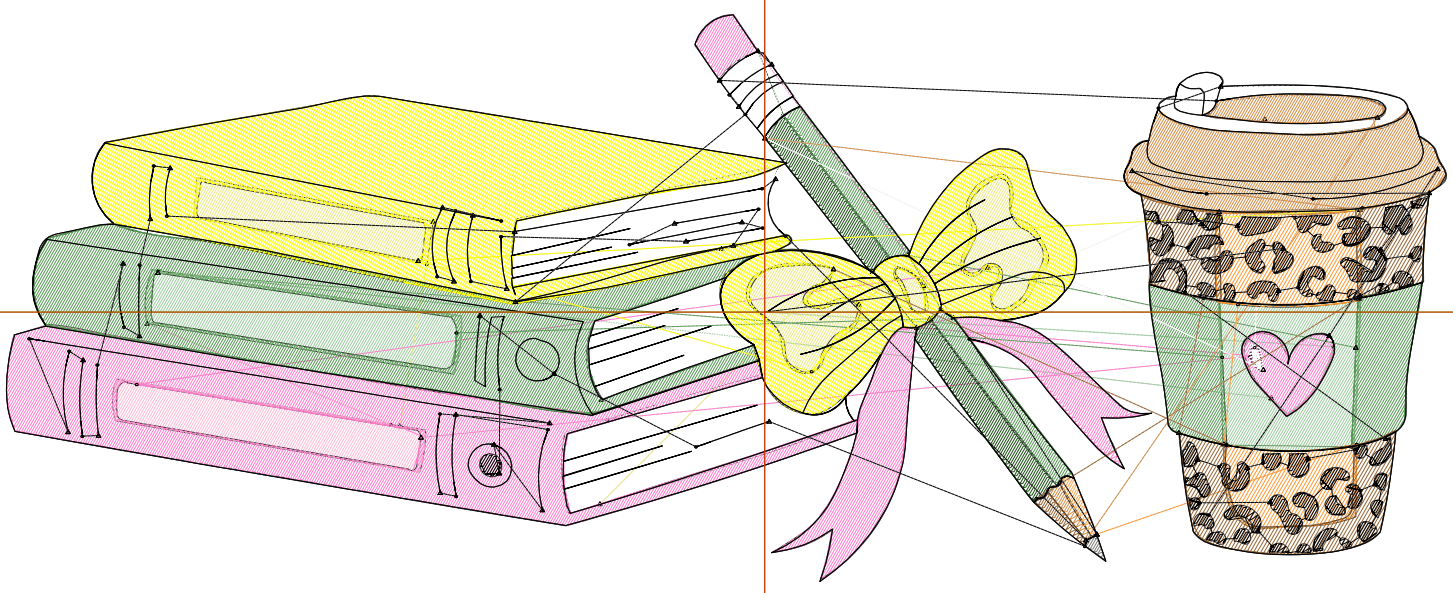

Production Worksheet

Wilcom EmbroideryStudio - Designing



Design: **7**

Title:

Stitches: 19,108
 Height: 2.95 in
 Width: 7.50 in
 Colors: 14
 Colorway: Colorway 1
 Zoom: 1:1

Machine format: Tajima
 Color changes: 15
 Stops: 16
 Trims: 88
 Appliqués: 0
 Left: 100.3 mm
 Right: 90.1 mm
 Up: 39.4 mm
 Down: 35.6 mm
 EndX: 0.00 in
 EndY: 0.00 in
 Area 22.14 in²
 Max stitch: 10.7 mm
 Min stitch: 0.0 mm
 Max jump: 7.0 mm
 Total thread: 285.47ft
 Total bobbin: 91.76ft

Stop Sequence:

| # | N# | Color | St. | Code | Name | Chart |
|-----|----|-------|-------|------|----------------|---------|
| 1. | 3 | | 1,062 | | R158 G204 B160 | |
| 2. | 2 | | 478 | | R255 G188 B213 | |
| 3. | 5 | | 371 | | R235 G235 B138 | |
| 4. | 9 | | 1,327 | 9 | White | Default |
| 5. | 5 | | 501 | | R235 G235 B138 | |
| 6. | 15 | | 2,849 | 15 | Pink | Default |
| 7. | 7 | | 475 | | R27 G79 B20 | |
| 8. | 1 | | 2,729 | | R88 G153 B85 | |
| 9. | 9 | | 629 | 9 | White | Default |
| 10. | 6 | | 926 | | R212 G141 B71 | |
| 11. | 10 | | 60 | | R255 G170 B85 | |
| 12. | 11 | | 35 | | R127 G128 B122 | |
| 13. | 12 | | 498 | 12 | Orange | Default |
| 14. | 4 | | 3,020 | 4 | Yellow | Default |
| 15. | 14 | | 718 | 14 | Brown | Default |
| 16. | 8 | | 3,428 | 8 | Black | Default |