

Production Worksheet

Wilcom EmbroideryStudio - Designing



Design: **3**

Title:

Stitches: 19,192
 Height: 3.51 in
 Width: 2.77 in
 Colors: 4
 Colorway: Colorway 1
 Zoom: 1:1

Machine format: Tajima
 Color changes: 3
 Stops: 4
 Trims: 93
 Appliqués: 0
 Left: 36.1 mm
 Right: 34.4 mm
 Up: 43.0 mm
 Down: 46.1 mm
 EndX: 0.00 in
 EndY: 0.00 in
 Area 9.73 in²
 Max stitch: 7.2 mm
 Min stitch: 0.0 mm
 Max jump: 6.9 mm
 Total thread: 232.12ft
 Total bobbin: 62.15ft

Stop Sequence:

| # | N# | Color | St. | Code | Name | Chart |
|----|----|--|--------|------|----------------|---------|
| 1. | 3 | | 693 | 3 | Red | Default |
| 2. | 18 | | 7,017 | 18 | Grey | Default |
| 3. | 2 | | 926 | | R166 G166 B166 | |
| 4. | 8 | | 10,554 | 8 | Black | Default |

DAD
= FIXES =
EVERYTHING

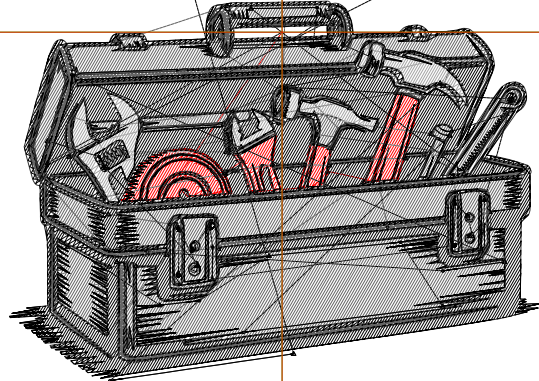

Production Worksheet

Wilcom EmbroideryStudio - Designing



Design: **4**

Title:

Stitches: 22,317
Height: 4.01 in
Width: 3.17 in
Colors: 4
Colorway: Colorway 1
Zoom: 1:1

Machine format: Tajima
Color changes: 3
Stops: 4
Trims: 97
Appliqués: 0
Left: 41.1 mm
Right: 39.4 mm
Up: 49.3 mm
Down: 52.4 mm
EndX: 0.00 in
EndY: 0.00 in
Area: 12.70 in²
Max stitch: 8.1 mm
Min stitch: 0.0 mm
Max jump: 7.0 mm
Total thread: 278.20ft
Total bobbin: 77.30ft

Stop Sequence:

| # | N# | Color | St. | Code | Name | Chart |
|----|----|-------|--------|------|----------------|---------|
| 1. | 3 | | 829 | 3 | Red | Default |
| 2. | 18 | | 8,192 | 18 | Grey | Default |
| 3. | 2 | | 1,067 | | R166 G166 B166 | |
| 4. | 8 | | 12,227 | 8 | Black | Default |

DAD
= FIXES =
EVERYTHING

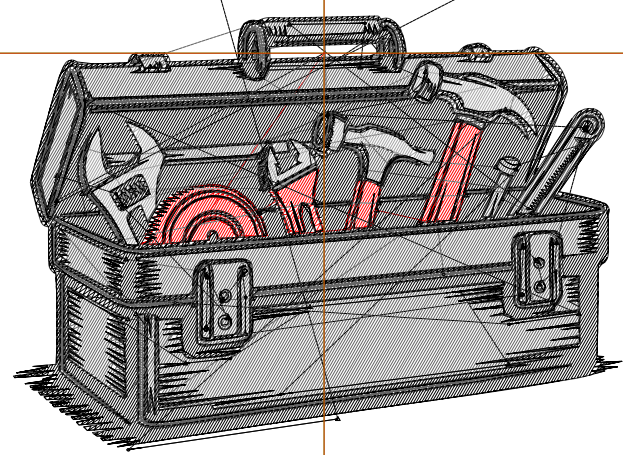

Production Worksheet

Wilcom EmbroideryStudio - Designing



Design: **4**

Title:

Stitches: 25,559
Height: 4.51 in
Width: 3.56 in
Colors: 4
Colorway: Colorway 1
Zoom: 1:1

Machine format: Tajima
Color changes: 3
Stops: 4
Trims: 99
Appliqués: 0
Left: 46.1 mm
Right: 44.3 mm
Up: 55.7 mm
Down: 58.8 mm
EndX: 0.00 in
EndY: 0.00 in
Area: 16.05 in²
Max stitch: 9.1 mm
Min stitch: 0.0 mm
Max jump: 6.9 mm
Total thread: 326.40ft
Total bobbin: 93.26ft

Stop Sequence:

| # | N# | Color | St. | Code | Name | Chart |
|----|----|-------|--------|------|----------------|---------|
| 1. | 3 | | 985 | 3 | Red | Default |
| 2. | 18 | | 9,346 | 18 | Grey | Default |
| 3. | 2 | | 1,226 | | R166 G166 B166 | |
| 4. | 8 | | 14,000 | 8 | Black | Default |

DAD
=FIXES=
EVERYTHING

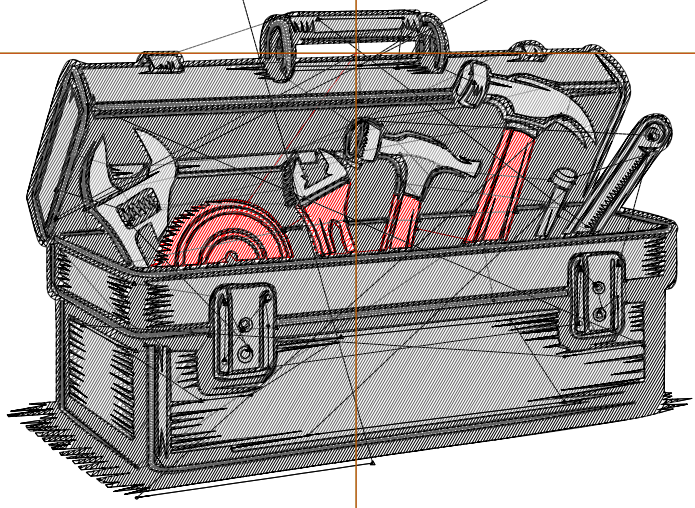

Production Worksheet

Wilcom EmbroideryStudio - Designing



Design: **5**

Title:

Stitches: 28,998
Height: 5.01 in
Width: 3.96 in
Colors: 4
Colorway: Colorway 1
Zoom: 1:1

Machine format: Tajima
Color changes: 3
Stops: 4
Trims: 100
Appliqués: 0
Left: 51.2 mm
Right: 49.5 mm
Up: 62.0 mm
Down: 65.1 mm
EndX: 0.00 in
EndY: 0.00 in
Area: 19.83 in²
Max stitch: 10.1 mm
Min stitch: 0.0 mm
Max jump: 7.0 mm
Total thread: 381.64ft
Total bobbin: 112.62ft

Stop Sequence:

| # | N# | Color | St. | Code | Name | Chart |
|----|----|-------|--------|------|----------------|---------|
| 1. | 3 | Red | 1,088 | 3 | Red | Default |
| 2. | 18 | Grey | 10,601 | 18 | Grey | Default |
| 3. | 2 | Grey | 1,391 | | R166 G166 B166 | |
| 4. | 8 | Black | 15,916 | 8 | Black | Default |

DAD
= FIXES =
EVERYTHING

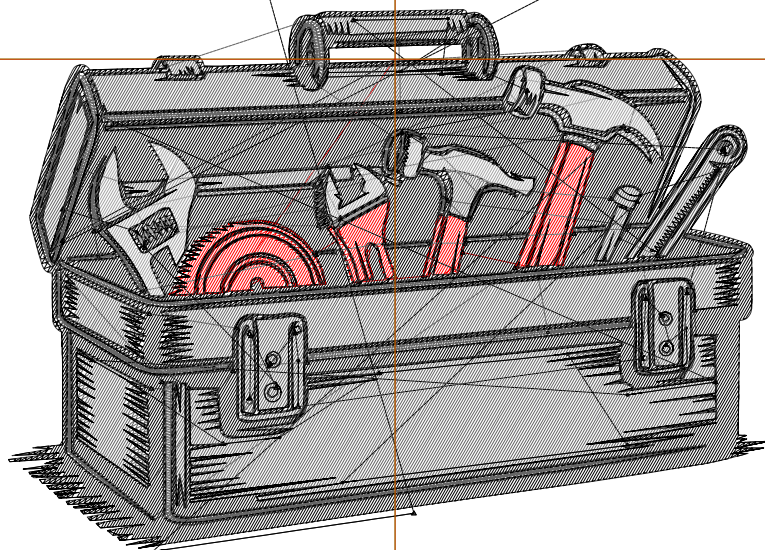

Production Worksheet

Wilcom EmbroideryStudio - Designing



Design: **5**

Title:

Stitches: 32,456
Height: 5.51 in
Width: 4.35 in
Colors: 4
Colorway: Colorway 1
Zoom: 1:1

DAD
= FIXES =
EVERYTHING

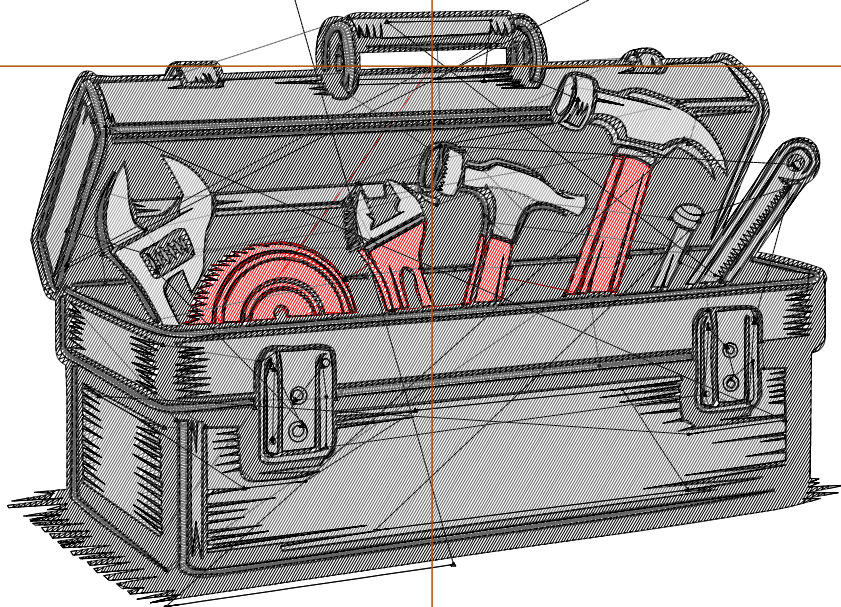

Machine format: Tajima
Color changes: 3
Stops: 4
Trims: 101
Appliqués: 0
Left: 56.2 mm
Right: 54.3 mm
Up: 68.4 mm
Down: 71.5 mm
EndX: 0.00 in
EndY: 0.00 in
Area: 23.95 in²
Max stitch: 11.1 mm
Min stitch: 0.0 mm
Max jump: 6.9 mm
Total thread: 436.90ft
Total bobbin: 131.92ft

Stop Sequence:

| # | N# | Color | St. | Code | Name | Chart |
|----|----|-------|--------|------|----------------|---------|
| 1. | 3 | Red | 1,256 | 3 | Red | Default |
| 2. | 18 | Grey | 11,911 | 18 | Grey | Default |
| 3. | 2 | Grey | 1,510 | | R166 G166 B166 | |
| 4. | 8 | Black | 17,777 | 8 | Black | Default |

Production Worksheet

Wilcom EmbroideryStudio - Designing



Design: **6**

Title:

Stitches: 36,276
Height: 6.01 in
Width: 4.75 in
Colors: 4
Colorway: Colorway 1
Zoom: 1:1

DAD
= FIXES =
EVERYTHING

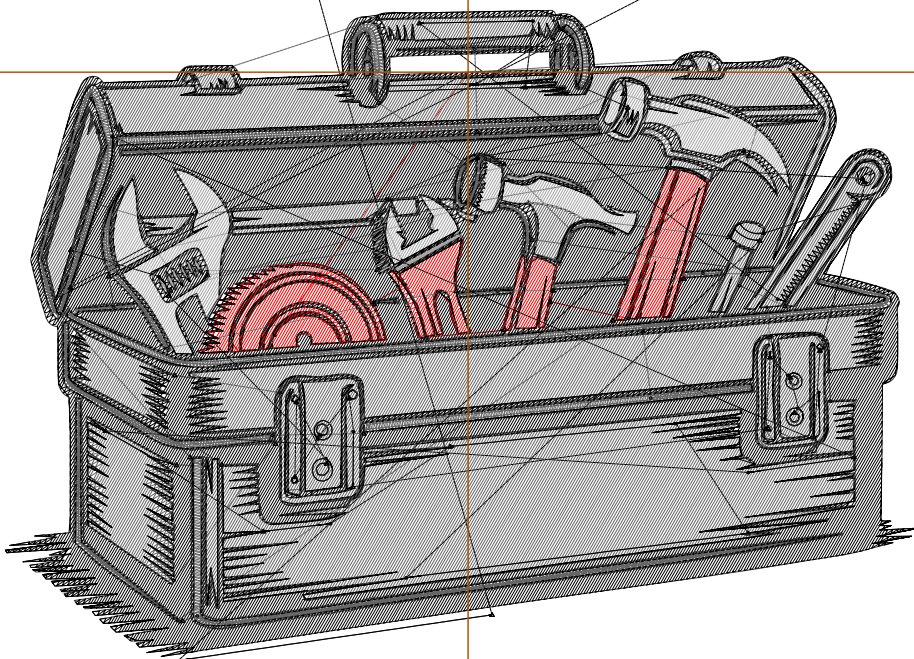

Machine format: Tajima
Color changes: 3
Stops: 4
Trims: 102
Appliqués: 0
Left: 61.2 mm
Right: 59.5 mm
Up: 74.7 mm
Down: 77.8 mm
EndX: 0.00 in
EndY: 0.00 in
Area: 28.56 in²
Max stitch: 12.0 mm
Min stitch: 0.0 mm
Max jump: 7.0 mm
Total thread: 498.62ft
Total bobbin: 153.65ft

Stop Sequence:

| # | N# | Color | St. | Code | Name | Chart |
|----|----|-------|--------|------|----------------|---------|
| 1. | 3 | Red | 1,379 | 3 | Red | Default |
| 2. | 18 | Grey | 13,277 | 18 | Grey | Default |
| 3. | 2 | | 1,667 | | R166 G166 B166 | |
| 4. | 8 | Black | 19,951 | 8 | Black | Default |

Production Worksheet

Wilcom EmbroideryStudio - Designing



Design: **6**

Title:

Stitches: 40,328
Height: 6.51 in
Width: 5.15 in
Colors: 4
Colorway: Colorway 1
Zoom: 1:1

**DAD
= FIXES =
EVERYTHING**

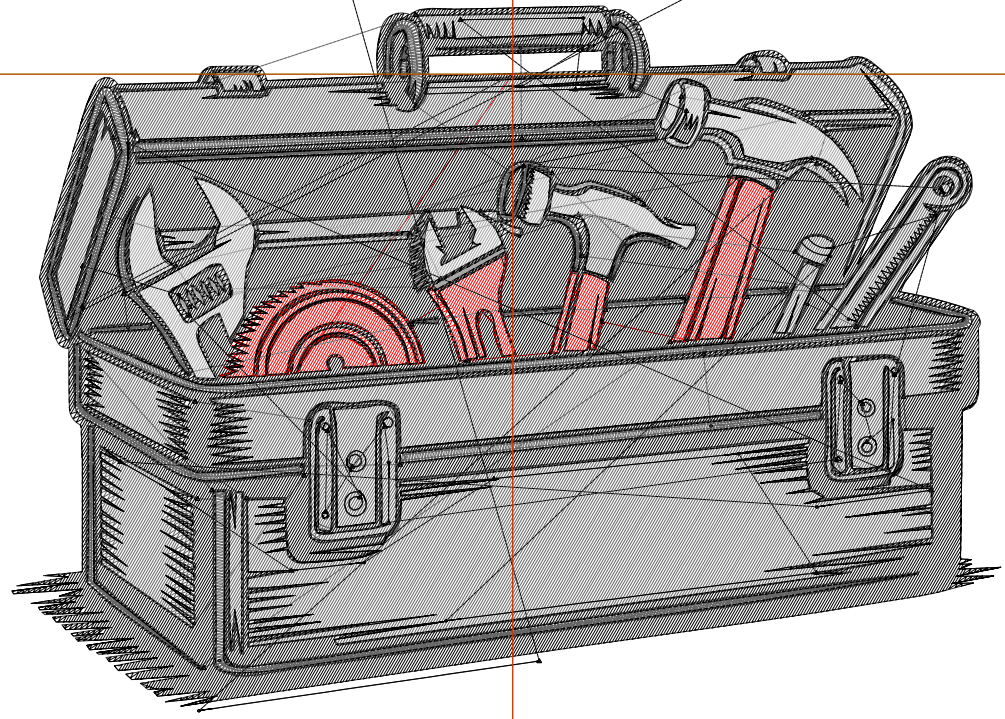

Production Worksheet

Wilcom EmbroideryStudio - Designing



Design: **6**

Title:

Stitches: 40,328
 Height: 6.51 in
 Width: 5.15 in
 Colors: 4
 Colorway: Colorway 1
 Zoom: 1:1

Machine format: Tajima
 Color changes: 3
 Stops: 4
 Trims: 102
 Appliqués: 0
 Left: 66.3 mm
 Right: 64.6 mm
 Up: 81.1 mm
 Down: 84.2 mm
 EndX: 0.00 in
 EndY: 0.00 in
 Area 33.51 in²
 Max stitch: 12.0 mm
 Min stitch: 0.0 mm
 Max jump: 7.0 mm
 Total thread: 565.96ft
 Total bobbin: 177.79ft

Stop Sequence:

| # | N# | Color | St. | Code | Name | Chart |
|----|----|-------|--------|------|----------------|---------|
| 1. | 3 | | 1,538 | 3 | Red | Default |
| 2. | 18 | | 14,740 | 18 | Grey | Default |
| 3. | 2 | | 1,804 | | R166 G166 B166 | |
| 4. | 8 | | 22,244 | 8 | Black | Default |

Production Worksheet

Wilcom EmbroideryStudio - Designing



Design: 7

Title:

Stitches: 44,373
Height: 7.01 in
Width: 5.55 in
Colors: 4
Colorway: Colorway 1
Zoom: 1:1

DAD
= FIXES =
EVERYTHING

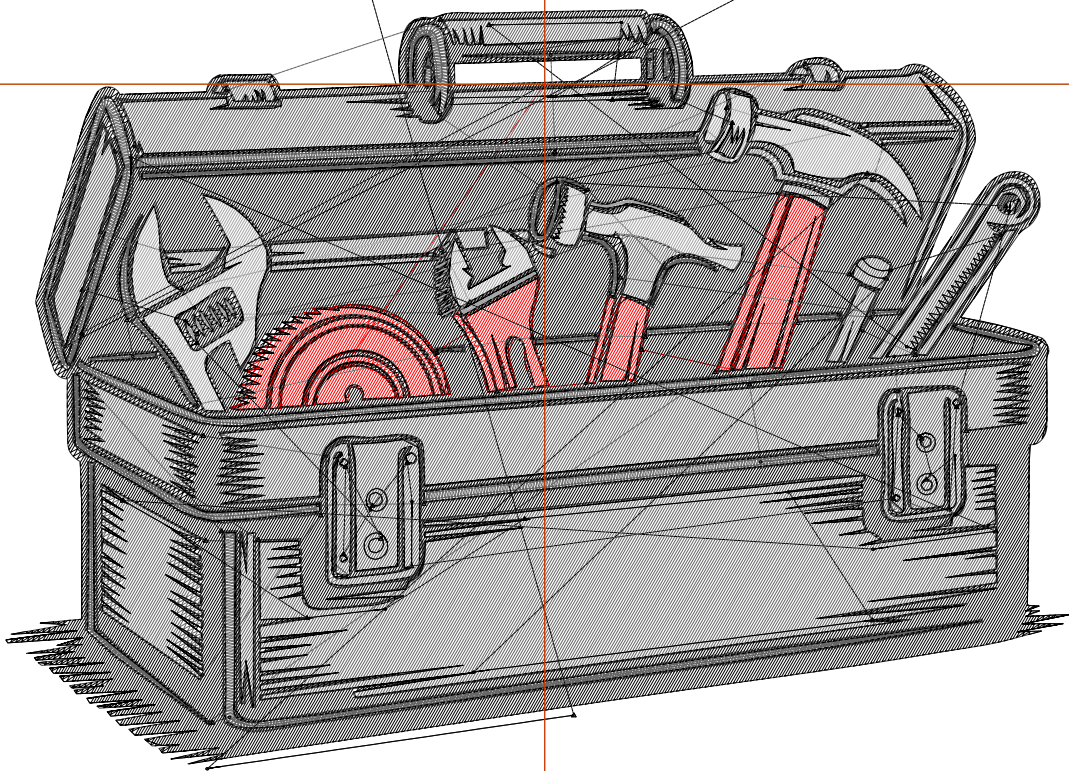

Production Worksheet

Wilcom EmbroideryStudio - Designing



Design: **7**

Title:

Stitches: 44,373
 Height: 7.01 in
 Width: 5.55 in
 Colors: 4
 Colorway: Colorway 1
 Zoom: 1:1

Machine format: Tajima
 Color changes: 3
 Stops: 4
 Trims: 102
 Appliqués: 0
 Left: 71.3 mm
 Right: 69.6 mm
 Up: 87.4 mm
 Down: 90.5 mm
 EndX: 0.00 in
 EndY: 0.00 in
 Area 38.86 in²
 Max stitch: 12.0 mm
 Min stitch: 0.0 mm
 Max jump: 7.0 mm
 Total thread: 635.27ft
 Total bobbin: 203.14ft

Stop Sequence:

| # | N# | Color | St. | Code | Name | Chart |
|----|----|-------|--------|------|----------------|---------|
| 1. | 3 | | 1,688 | 3 | Red | Default |
| 2. | 18 | | 16,207 | 18 | Grey | Default |
| 3. | 2 | | 1,997 | | R166 G166 B166 | |
| 4. | 8 | | 24,479 | 8 | Black | Default |

Production Worksheet

Wilcom EmbroideryStudio - Designing



Design: 7

Title:

Stitches: 48,361
Height: 7.51 in
Width: 5.94 in
Colors: 4
Colorway: Colorway 1
Zoom: 1:1

DAD
= FIXES =
EVERYTHING

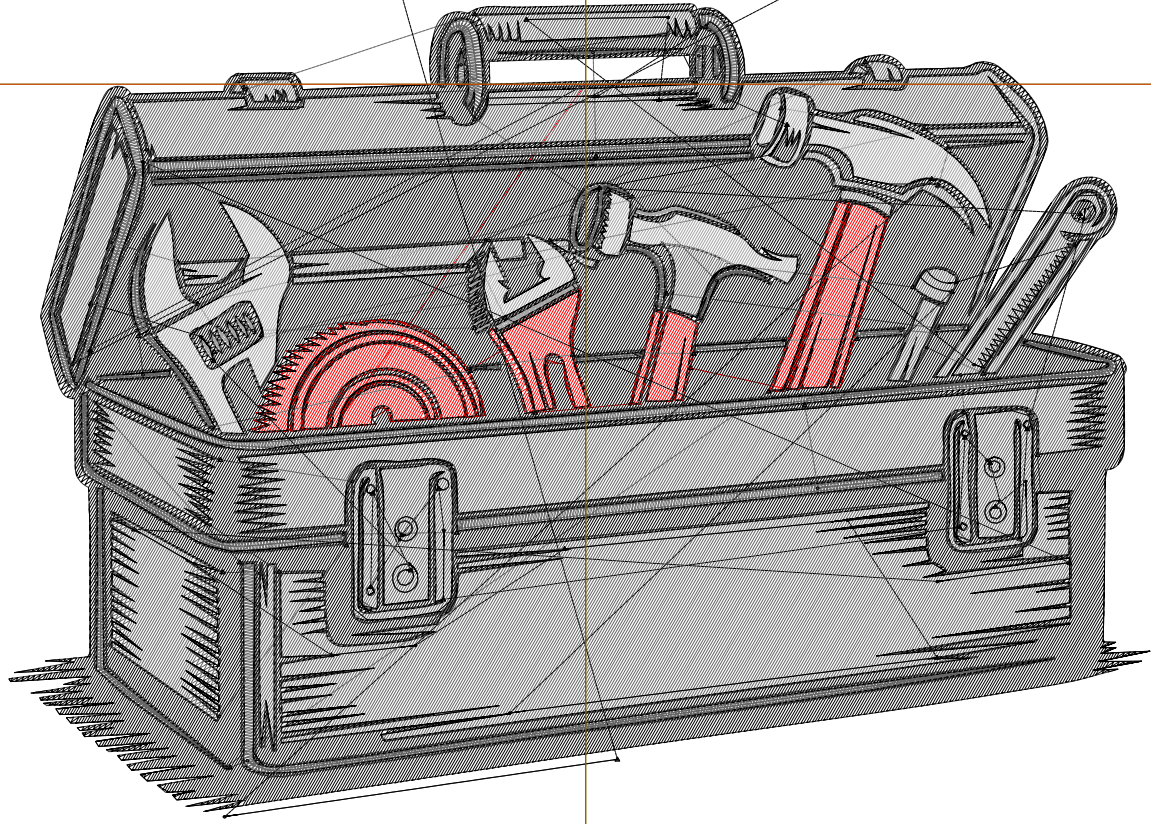

Production Worksheet

Wilcom EmbroideryStudio - Designing



Design: **7**

Title:

Stitches: 48,361
 Height: 7.51 in
 Width: 5.94 in
 Colors: 4
 Colorway: Colorway 1
 Zoom: 1:1

Machine format: Tajima
 Color changes: 3
 Stops: 4
 Trims: 103
 Appliqués: 0
 Left: 76.3 mm
 Right: 74.6 mm
 Up: 93.8 mm
 Down: 96.9 mm
 EndX: 0.00 in
 EndY: 0.00 in
 Area 44.59 in²
 Max stitch: 12.0 mm
 Min stitch: 0.0 mm
 Max jump: 7.0 mm
 Total thread: 706.10ft
 Total bobbin: 229.61ft

Stop Sequence:

| # | N# | Color | St. | Code | Name | Chart |
|----|----|-------|--------|------|----------------|---------|
| 1. | 3 | | 1,867 | 3 | Red | Default |
| 2. | 18 | | 17,573 | 18 | Grey | Default |
| 3. | 2 | | 2,188 | | R166 G166 B166 | |
| 4. | 8 | | 26,731 | 8 | Black | Default |